

# QUICK START GUIDE

## PARAMETER LIST

FP FEP-14 / iSP RCF  
FrigoSoft 2.6

REFR/COOL

FS 2.6.2-x

USA units

Automatic to OPERATOR menu approx. 2 s after switching on

FrigoSoft26.2_2a XXX14-6 1.3x	OPERATOR menu at level 1	01:ts td TEMP Y.Y YY.Y °C	
		02:te tc TEMP Y.Y YY.Y °C	
		03:pe pc PRES Y.Y YY.Y bar	
		04:pe pc P DV Y.Y Y.Y%	
		06:VsC OIL PRESS Y.Y bar	
		07:VsC ELEC A Hz Y.Y Y.Y Hz	
		08:Fsc ACTV_POSS Y Y	
		10:CONDEN % tamb YY.Y YY.Y °C	
		30:pe MINIMUM → 2.5 bar	-16 °C*
		31:pe SETPOINT 1 → 3.3 bar	-10 °C*
		32:pe SETPOINT 2 → 3.8 bar	-7 °C*
		39:pe MAXIMUM → 6.0 bar	7 °C*
		41:pc SETPOINT 1 → 17.3 bar	40 °C*
		42:pc SETPOINT 2 → 20.1 bar	46 °C*
		49:pc MAXIMUM → 23.0 bar	51 °C*
		50:REFRIGERANT → R404A	
		61:VsC CURR MAX → FFF.FF A	
		62:VsC FREQ MAX → 60.0 Hz	
		65:VsC FREQ MIN → 25.0 Hz	
		66:VsC SKIP FREQ → 0.0 Hz	
		67:VsC SKIP BAND → 0.0 Hz	
		70:VsC tinh TIME → FFF.F s	
		71:VsC thld TIME → 10.0 s	
		74:VsC tmon fmin → 600.0 s	
		76:VsC toil STRT → 4.0 s	
		77:VsC poil MIN → 0.8 bar	
		81:Fsc ton DLY → FFF.0 s	
		82:Fsc toff DLY → FF.0 s	
		83:Fsc NUMBER → 1	
		91:pe CNTRL P-GN → F.00	
		92:pc CNTRL P-GN → 10.0	
		93:VsF CD MIN SD → 15.00	
		94:pc LIMIT P-GN → 25.00	
		A1:AOUT1 FUNCTN → INPUT 0	
		A2:AOUT2 FUNCTN → INPUT 0	
		A3:AOUT3 FUNCTN → INPUT 1	
		A4:DOUT1 FUNCTN → INPUT 2	
		A6:CONTRL FUNCTN → 0000	
		A9:LANGUAGE → ENGLISH	

Type	Description	Further information
Measured values	Compressor rack: Suction and discharge gas temp. <span style="background-color: yellow;">Optional use</span>	9.1.1
Measured values	Compressor rack: Saturated evaporat. and condens. temp.	
Measured values	Compressor rack: Evaporating and condensing pressure	
Deviations	Compressor rack: Evaporating and condensing pressure	
Measured value	Variable-speed Compressor: Oil pressure <span style="background-color: yellow;">Optional use</span>	9.1.2
Measured values	Variable-speed Compressor: Motor current, Motor frequency	
Measured values	Fixed-speed Compressors: Number active / possible	9.1.1
Measured values	Condenser: Variable-speed fan / Ambient	9.1.3
Limit value	pe, Stop value "Pump Down limit": -0.5 ... 7.0 bar	8.3.2
Setting 1	pe1, Setpoint 1: -0.5 ... 7.0 bar	
Setting 2	pe2, Setpoint 2: -0.5 ... 7.0 bar	
Limit value	pe, Maximum value: -0.5 ... 7.0 bar	
Setting 1	pc, Setpoint 1: 0.0 ... 30.0 bar	8.3.4
Setting 2	pc, Setpoint 2: 0.0 ... 30.0 bar	
Limit value	pc, High Limit: 0.0 ... 30.0 bar	
Selection	Refrigerant: R404A, R507C, R407C, R410A, R717, R134a, R22, ...	8.3.5
Limit value	VsC, Maximum current: 0.00 ... 999.99 A	8.4.1
Limit value	VsC, Maximum frequency: 15.0 ... 90.0 Hz	
Limit value	VsC, Minimum frequency: 15.0 ... 90.0 Hz	
Setting	VsC, Skip frequency: 15.0 ... 90.0 Hz	8.4.2
Setting	VsC, Skip frequency band: 0.0 ... 10.0 Hz	
Limit value	VsC, Minimum OFF time: 0.1 ... 3000.0 s	8.4.3
Setting	VsC, Hold time (time at fmin following oil pulse): 0.1 ... 3000.0 s	
Setting	VsC: Monitoring time at fmin: 0.0 ... 3000.0 s	
Setting	VsC, Oil lubrication pulse time: 0.1 ... 3000.0 s	8.4.4
Limit value	VsC: Minimum oil pressure <span style="background-color: yellow;">Optional use</span> -0.5 ... 7.0 bar	
Setting	FsC, Switch-on delay: 0.1 ... 3000.0 s	8.5.1
Setting	FsC, Switch-off delay: 0.1 ... 3000.0 s	
Selection	FsC, Number of compressors: 0 ... 7	
Setting	pe controller, Proportional gain: 0.10 ... 100.00	8.6.1
Setting	pc controller, Proportional gain: 0.1 ... 100.0	8.6.2
Setting	Var.-speed Fan, cond., min. speed: 0.00 ... 100.00	
Setting	pc limiter, Proportional gain: 0.00 ... 100.00	
Selection	AOUT1 - Function selection: INPUT 0...3 (VsF)	8.7.1
Selection	AOUT2 - Function selection: INPUT 0...3 (FsC2)	
Selection	AOUT3 - Function selection: INPUT 0...7 (FsC3)	
Selection	DOUT1 - Function selection: INPUT 0...7 (CC)	
Selection	FrigoSoft - Function selection: 0000 ... 0033	8.7.2
Selection	Language selection: ENGLISH ... NEDERLANDS	8.7.3

\* Factory setting for R404A

### Key for abbreviations

VsC: Variable-speed Compressor  
FsC: Fixed-speed Compressor  
VsF: Variable-speed fans (Condenser / Dry cooler)

= YYY.YY %  
→ FFF.0 s

### FIRST TIME POWER UP: Go to page 11

Measured value depending on operating point  
Factory default value depending on frame size and rated power

**Explanation of adjustable operating pressures:**

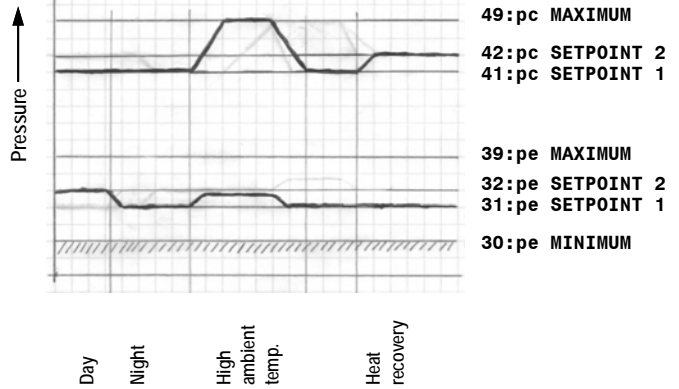

**Suggested refrigeration settings:**

Based on EN 12900

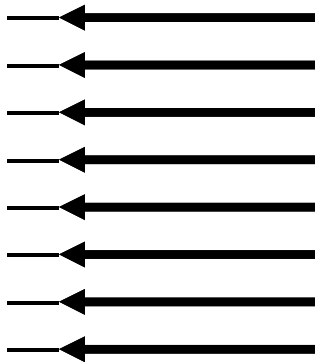

30:pe MINIMUM	→ 2.5 bar
31:pe SETPOINT 1	→ 3.3 bar
32:pe SETPOINT 2	→ 3.8 bar
39:pe MAXIMUM	→ 6.0 bar
41:pc SETPOINT 1	→ 17.3 bar
42:pc SETPOINT 2	→ 20.1 bar
49:pc MAXIMUM	→ 23.0 bar
50:REFRIGERANT	→ R404A

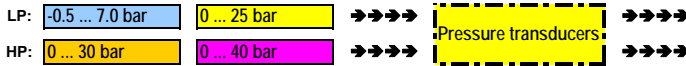

**Factory setting**

R404A / R507			R407C		R22			R134a		R410A	
LT	MT	HT	MT	HT	LT	MT	HT	MT	HT	MT	HT
-40 °C/ 0.3	-16 °C/ 2.5	0 °C/ 5.0	-16 °C/ 1.5	0 °C/ 3.6	-37 °C/ 0.2	-16 °C/ 1.9	0 °C/ 4.0	-16 °C/ 0.6	0 °C/ 1.9	-16 °C/ 3.6	0 °C/ 7.0
-35 °C/ 0.6	-10 °C/ 3.3	5 °C/ 6.0	-10 °C/ 2.2	5 °C/ 4.5	-32 °C/ 0.5	-10 °C/ 2.6	5 °C/ 4.8	-10 °C/ 1.0	5 °C/ 2.5	-10 °C/ 4.7	5 °C/ 8.3
-30 °C/ 1.0	-7 °C/ 3.8	8 °C/ 6.7	-7 °C/ 2.6	8 °C/ 5.0	-30 °C/ 0.6	-7 °C/ 2.9	8 °C/ 5.4	-7 °C/ 1.3	8 °C/ 2.9	-7 °C/ 5.3	8 °C/ 9.2
5 °C/ 6.0	5 °C/ 6.0	5 °C/ 6.0	10 °C/ 5.5	10 °C/ 5.5	10 °C/ 6.8	10 °C/ 6.8	10 °C/ 6.8	12 °C/ 3.4	12 °C/ 3.4	12 °C/ 10.5	12 °C/ 10.5
40... °C/ 17.3	40... °C/ 17.3	40... °C/ 17.3	40... °C/ 16.5	40... °C/ 16.5	40... °C/ 14.3	40... °C/ 14.3	40... °C/ 14.3	40... °C/ 9.2	40... °C/ 9.2	40... °C/ 23.3	40... °C/ 23.3
46... °C/ 20.1	46... °C/ 20.1	46... °C/ 20.1	46... °C/ 19.2	46... °C/ 19.2	46... °C/ 16.7	46... °C/ 16.7	46... °C/ 16.7	46... °C/ 10.9	46... °C/ 10.9	46... °C/ 27.0	46... °C/ 27.0
52 °C/ 23.0	52 °C/ 23.0	52 °C/ 23.0	52 °C/ 22.2	52 °C/ 22.2	52 °C/ 19.3	52 °C/ 19.3	52 °C/ 19.3	55 °C/ 13.9	55 °C/ 13.9	55 °C/ 37.4	55 °C/ 37.4



Diagnosics

Electrical values:

DIAGNOSTICS menu at level 1	M	E
DRIVE FREQUENCY = YY.YY Hz		
MOTOR CURRENT A = YY.Y A		
MOTOR CURRENT % = YY.YY %		
DC LINK VOLTS = YYY V		
BASE FREQ ACTIVE = YY.Y Hz		
BASE VOLT ACTIVE = YYY.Y V		
TERMINAL VOLTS = YYY V		
TORQUE FEEDBACK = YY.YY %		
FIELD FEEDBACK = YY.YY %		
ELECTRICAL POWER = YY.Y kW		
ELECTRICAL ENERGY = YYY kWh		
SC STAGE NUMBER = Y		
SC CAPACITY CNTR = YYYYY		
SC OUTPUT = YYY		
SCC OUTPUT 1 = YYYYY		
SCC OUTPUT 2 = YYYYY		
SCC OUTPUT 3 = YYYYY		
SCC OUTPUT 4 = YYYYY		
SC CAPACITY = Y.YY		
SC CAPACITY % = YY.YY %		
SC DIAGNOSTIC = Y		

Stage controller:

Internal value	Variable-speed Compressor: Motor Frequency	9.2.1
Measured value	Variable-speed Compressor: Motor current [A]	
Internal value	Variable-speed Compressor: Motor current [%]	
Measured value	Variable-speed Compressor: DC link voltage	
Internal value	Variable-speed Compressor: Active base frequency	
Internal value	Variable-speed Compressor: Active base voltage	
Measured value	Variable-speed Compressor: Motor voltage	
Internal value	Variable-speed Compressor: Calculated torque	
Internal value	Variable-speed Compressor: Calculated magnetic motor field	
Measured value	Variable-speed Compressor / Rack: Calculated / Measured electrical power	
Measured value	Variable-speed Compressor / Rack: Calculated / Measured electrical energy	
Internal value	Compressor rack: Number of stages	9.2.2
Command	Compressor rack: Capacity Control activated	
Internal value	Compressor rack: Output control signal	
Command	Compressor rack: Output control signal 1	
Command	Compressor rack: Output control signal 2	
Internal value	Compressor rack: Output control signal 3	
Internal value	Compressor rack: Output control signal 4	
Internal value	Compressor rack: Calculated total power	
Internal value	Compressor rack: Calculated total power in %	
Internal value	Compressor rack: Diagnostics	

**Analog inputs:**

ANALOG INPUT 1 = YYY.YY %
ANALOG INPUT 2 = YYY.YY %
ANALOG INPUT 3 = YYY.YY %
ANALOG INPUT 4 = YYY.YY %
ANALOG OUTPUT 1 = YYY.YY %
ANALOG OUTPUT 2 = YYY.YY %
ANALOG OUTPUT 3 = YYY.YY %
DIGITAL I/O = YYYY >>

**Analog outputs:**

**Digital inputs:**

DIGITAL INPUT 1 = YYYYY	1
DIGITAL INPUT 2 = YYYYY	2
DIGITAL INPUT 3 = YYYYY	4
DIGITAL INPUT 4 = YYYYY	8
DIGITAL INPUT 5 = YYYYY	1
DIGITAL INPUT 6 = YYYYY	2
DIGITAL INPUT 7 = YYYYY	4
SAFETY CIRCUIT = YYYYY	8
DIGITAL OUTPUT 1 = YYYYY	1
DIGITAL OUTPUT 2 = YYYYY	2
DIGITAL OUTPUT 3 = YYYYY	4
ANALOG OUTPUT 1 = YYYYY	1
ANALOG OUTPUT 2 = YYYYY	2
ANALOG OUTPUT 3 = YYYYY	4

**Digital outputs:**

**Analog outputs used as relay outputs:**

**Setpoints:**

SPEED DEMAND = YYY.YY %
REMOTE SETPOINT = YYY.YY %
FREQ SETPOINT = YY.YY Hz
COMMS SETPOINT = YYY.YY %
LOCAL SETPOINT = YYY.YY %
JOG SETPOINT = 10.00 %

**Trips:**

ACTIVE TRIPS = YYYY >>
ACTIVE TRIPS+ = YYYY >>
WARNINGS = YYYY >>
WARNINGS+ = YYYY >>
FIRST TRIP = TTY:YYYYYYYYYY
TRIP 1 (NEWEST) = TTY:YYYYYYYYYY
TRIP 1 TIME = YYYYYYYYYY s

**State indications:**

TRIP 10 (OLDEST) = TTY:YYYYYYYYYY
TRIP 10 TIME = YYYYYYYYYY s
TIME IN SERVICE = YYYYYYYYYY s
TIME RUNNING = YYYYYYYYYY s
START COUNT = YYYYYYYYYY
ATTEMPTS LEFT = YY
TIME LEFT = YYYY.Y s
BRAKING = YYYY
SEQUENCER STATE = YYYYYYYYYYYYYY
MOTOR STATE = YYYYYYYYYYYYYY

AIN1 (X2:2) Analog input 1	pe, Suction-pressure transducer: 4 ... 20 mA; 0.0 ... 100.0 %	6.3.1 /
AIN2 (X2:3) Analog input 2	pc, High-pressure transducer: 4 ... 20 mA; 0.0 ... 100.0 %	
AIN3 (X2:4) Analog input 3	Exhaust gas or ambient temperature: PT1000	
AIN4 (X2:5) Analog input 4	Ext. act. value / setpoint: 0 ... 10 V; 0.0 ... 100.0 %	
AOUT1 (X2:6) Analog output 1	VsF condenser / VsC speed / Hot-gas bypass / -	6.3.2
AOUT2 (X2:7S-7G) Analog output 2	- / VsC speed / Hot gas bypass / -	
Analog output 3	Not used	
Menü	Digital inputs and outputs	5.2

DIN1 (X2:12) Digital input 1	Enable (Start)	5.2.1-4
DIN2 (X2:13) Digital input 2	Force lubrication speed	5.3
DIN3 (X2:14) Digital input 3	Activate Setpoint / Limit pe2	5.2.2/4
DIN4 (X2:15) Digital input 4	NOT activate Setpoint / Limit pe1	
DIN5 (X2:16) Digital input 5	Activate Setpoint pc2	5.3
DIN6 (X2:17) Digital input 6	FsC Safety circuits without fault / Activate VsC continuous operation	5.3
DIN7 (X2:18) Digital input 7	Activate emergency operation	5.3
DIN8 (X2:19) Digital input 8	Safety circuit "Ready" (No fault)	5.4
DOUT1 (X:21-22) Digital output 1	Ready (Health)	6.3.4
DOUT2 (X2:23-24) Digital output 2	Operating	6.3.4
DOUT3 (X2:25-26) Digital output 3	Activate FsC1 (Fixed-speed Compressor 1)	6.3.4
AOUT1 (X2:6) Analog output 1	- / - / - / No pc limiting	6.3.2
AOUT2 (X3:7A-7B) Digital output A2	Activate FsC2 - / - / - / No pc limiting	6.3.4
AOUT3 (X3:8A-8B) Digital output A3	Activate FsC3 / Capacity Control / Min. capacity / Min. capacity delayed / No pc limiting / Swop compressor	6.3.4

Internal value	VsC: Actuating value of Freq.: % of maximum frequency	8.1.13
Internal value	Remote setpoint: % of maximum frequency	
Internal value	VsC Frequency Setpoint: Frequency	
Internal value	Comms command setpoint: % of maximum frequency	
Internal value	Local setpoint: % of maximum frequency	
Internal value	Jog setpoint: % of maximum frequency	

Trips	Active trips: First set	10.2-4
Trips	Active trips: Second set	
Warning	Warnings: First set	
Warning	Warnings: Second set	
Trip	Trip which caused shut down	
Trip	Trip 1 (newest) which caused shut down	
Trip	Time trip 1 occurred	
Trip	Trip 10 (oldest) which caused shut down	
Trip	Time trip 10 occurred	

Measured value	Time powered up	10.2-4
Measured value	Time VsC running	
Measured value	Number of VsC starts	
Internal value	Autorestart logic: Attempts left	
Internal value	Autorestart logic: Time to next start attempt	
Status	iSpeed: Chopper active	
Status	iSpeed operating status: Sequencer control state	
Status	VsC operating status: Sequencer control state	

QUICK SETUP menu at level 1

LANGUAGE	→ ENGLISH
APPLICATION	→ SAVED APP
ACCESS LEVEL	→ OPERATOR
SELECT UNITS 1	→ DEFAULT
SELECT UNITS 2	→ DEFAULT
SELECT UNITS 3	→ DEFAULT
SELECT UNITS 4	→ DEFAULT
REFRIGERANT	→ R404A
DATA 1 VALUE 1	→ 0.00
DATA 1 VALUE 2	→ 1.00
DATA 1 VALUE 3	→ 614.75
DATA 1 VALUE 4	→ -281.64
DATA 1 VALUE 5	→ 100.00
DATA 1 VALUE 6	→ 0.00
DATA 1 VALUE 7	→ 15.00
DATA 1 VALUE 8	→ 110.00
DATA 1 LOGIC 1	→ FALSE
DATA 1 LOGIC 2	→ FALSE
DATA 1 LOGIC 3	→ FALSE
DATA 1 LOGIC 4	→ FALSE
DATA 2 VALUE 1	→ 0.00
DATA 2 VALUE 2	→ 1.20
DATA 2 VALUE 3	→ 20.00
DATA 2 VALUE 4	→ 20.00
DATA 2 VALUE 5	→ 0.00
DATA 2 VALUE 6	→ 2.00
DATA 2 VALUE 7	→ 12.00
DATA 2 VALUE 8	→ 2.00
DATA 2 LOGIC 1	→ FALSE
DATA 2 LOGIC 2	→ FALSE
DATA 2 LOGIC 3	→ FALSE
DATA 2 LOGIC 4	→ FALSE
MAX FREQ	→ 60.00 Hz
MIN FREQ	→ 25.00 Hz
MOT RATED VOLTS	→ 400.0 V
MOT RATED FREQ	→ 50.00 Hz
MOT BASE FREQ	→ 55.00 Hz
MOT RATED CURRNT	→ YY.YY A
FIXED BOOST	→ YY.YY %
AUTO BOOST	→ YY.YY %
MIN BASE FREQ	→ 25.00 Hz
SKIP FREQ 1	→ 0.0 Hz
SKIP BAND 1	→ 0.0 Hz
SKIP FREQ 2	→ 0.0 Hz
SKIP BAND 2	→ 0.0 Hz

RFA  
RFB  
RFC

Selection	ENGLISH, DEUTSCH, FRANCAIS, ESPANOL, ITALIANO, SVENSK, POLSKI, PORTUGUES, NEDERLANDS
Selection	RHVAC Application
Selection	Menu access level
Selection	Displayed pressure units: DEFAULT: bar; ALTERNATE: psig
Selection	Displayed temperature units: DEFAULT: "C; ALTERNATE: "F
Selection	Not used
Selection	Not used
Selection	Refrigerant for calculation: p --> t; t --> p
Selection	Pressure Transducer pe [bar]: 0.00: -0.5...7.0   1.00: 0...25   2.00: 0...30   3.00: 0...60
Selection	Pressure Transducer pc [bar]: 0.00: 0...25   1.00: 0...30   2.00: 0...40   3.00: 0...160
Setting	Analog input AIN3: Scale (80.00 for tamb)
Setting	Analog input AIN3: Offset (-30.00 for tamb)
Setting	Analog input AIN4: Scale
Setting	Analog input AIN4: Offset
Setting	Suction line: Minimum superheat [K]
Setting	Discharge line: Maximum temperature [°C]
Selection	Temperature input AIN3: FALSE: td   TRUE: tamb
Selection	Digital input DIN6: Activate VsC not stop
Selection	Digital output DOUT1: Multiplexed multi function
Selection	Not used
Setting	Compensation for temperature glide tc (-2.00 with R407_v)
Setting	Factor for increase in fmin when limiting
Setting	Suction pressure controller: PID I time constant
Setting	Condensing pressure controller: PID I time constant
Setting	Not used
Setting	Hot-gas bypass: Gain reduction
Setting	tc-ta max. for floating condenser control [K]
Setting	tc-ta min. for floating condenser control [K]
Selection	Enable automatic oil speed up after delayed minimum capacity
Selection	Activate operation with hot-gas bypass
Selection	Show parameter: 01:ts   td TEMP
Selection	Show parameters: 06:VsC OIL PRESS; 77:VsC poil MIN
Setting	VsC: Maximum frequency Hz
Setting	VsC: Minimum frequency Hz
Setting	VsC: Motor rated voltage V
Setting	VsC: Motor rated frequency V
Setting	VsC: Motor base frequency Hz
Setting	VsC: Motor maximum current A
Setting	VsC: Motor fixed boost %
Setting	VsC: Motor auto boost %
Setting	VsC: Motor minimum base frequency Hz
Setting	VsC: Skip frequency 1 Hz
Setting	VsC: Skip band 1 Hz
Setting	VsC: Skip frequency 2 Hz
Setting	VsC: Skip band 2 Hz

Basic settings:

Special settings:

VsC motor settings:

Energy meter:

Serial communications:

Analog input types:

Compressor rack:

ENERGY MET RESET	→ FALSE
ENERGY MET MODE	→ INTERNAL
ENERGY MET SCALE	→ 1.0 kW
P3 EI ASCII UID	→ 1
MDBS RTU ADDRESS	→ 1
MDBS RTU PARITY	→ 0
AIN 1 TYPE	→ 4..20 mA
AIN 2 TYPE	→ 4..20 mA
AIN 3 TYPE	→ +1..+5 V
AIN 4 TYPE	→ 0..+10 V
SC FsD+ DELAY	→ FFF s
SC FsD+ FORCE	→ FALSE
SC FsD- DELAY	→ FF s
SC FsD- FORCE	→ FALSE
SC FsD RUN MAX	→ 6000 s
SC FsD RUN MIN	→ 60 s
SC FsD STOP MAX	→ 600 s
SC FsD STOP MIN	→ 60 s
SC CC ACTIVE MAX	→ 300 s
SC CC RECOVR MIN	→ 15 s
SC FAST STOP DLY	→ 2 s
SC FsD TOT OP RS	→ FALSE
SC FsD NMB ST RS	→ FALSE
SC STAGE NMB MAX	→ 1
SC LOGIC TYPE	→ 1
SC CODE TYPE	→ 0
SC CODE OFFSET	→ 0
SC CC OUT	→ 0
SC VsD CAPACITY	→ 100.00
SC VsD CC CPCTY	→ 100.00 %
SC FsD FREQ	→ 50.00 Hz
SC FsD0 CAPACITY	→ 100.00
SC FsD0 CC CPCTY	→ 0.00 %
SC FsD1 CAPACITY	→ 100.00
SC FsD1 CC CPCTY	→ 100.00 %
SC FsD2 CAPACITY	→ 100.00
SC FsD2 CC CPCTY	→ 100.00 %
SC FsD3 CAPACITY	→ 100.00
SC FsD3 CC CPCTY	→ 100.00 %
SC FsD4 CAPACITY	→ 100.00
SC FsD4 CC CPCTY	→ 100.00 %
SC CAPACITY TYPE	→ 1
SC DIAGNOST SEL	→ 1

Selection	Energy meter: Reset at FALSE --> TRUE --> FALSE
Selection	Energy meter: Mode: Internal= VsC; External= Rack
Setting	Energy meter: Scale: 1 kWh each pulse
Setting	P3 RS232 port with EI ASCII protocol: Unit Identifier address
Setting	RS485 Interface option: Modbus RTU address
Selection	RS485 Interface option: Modbus RTU parity
Selection	Analog input AIN1: Type
Selection	Analog input AIN2: Type
Selection	Analog input AIN3: Type
Selection	Analog input AIN4: Type
Setting	Stage controller: FsC switch-on delay
Selection	Stage controller, Manual force: One stage more at FALSE>TRUE>FALSE
Setting	Stage controller: FsC OFF delay
Selection	Stage controller, Manual force: One stage less at FALSE>TRUE>FALSE
Setting	Stage controller: FsC maximum run time
Setting	Stage controller: FsC minimum run time
Setting	Stage controller: FsC maximum stop time
Setting	Stage controller: FsC minimum stop time
Setting	Stage controller, Capacity Control: FsC CC maximum active time
Setting	Stage controller, Capacity Control: FsC CC minimum recovery time
Setting	Stage controller: FsC OFF delay at fast stop
Selection	Stage controller: FsC reset total operating times
Selection	Stage controller: FsC reset total start count
Setting	Stage controller: FsC maximum number of stages
Setting	Stage controller, FsC type of logic: 0: Normal; 1: Swop 1 (FsC); 2: Swop 2
Setting	Stage controller, FsC type of code: 0: MBC; 1: GBC; 2: MGBC
Setting	Stage controller: FsC code offset:
Setting	Stage controller: Internal Capacity Control output activated
Setting	Stage controller: Set VsD capacity
Setting	Stage controller: Set VsD capacity when capacity controlled
Setting	Stage controller: Set FsD frequency
Setting	Not used
Setting	Not used
Setting	Stage controller: Set FsD1 capacity
Setting	Stage controller: Set FsD1 capacity when capacity controlled
Setting	Stage controller: Set FsD2 capacity
Setting	Stage controller: Set FsD2 capacity when capacity controlled
Setting	Stage controller: Set FsD3 capacity
Setting	Stage controller: Set FsD3 capacity when capacity controlled
Setting	Stage controller: Set FsD4 capacity
Setting	Stage controller: Set FsD4 capacity when capacity controlled
Selection	Stage controller: Set capacity calculation type
Selection	Stage controller: Diagnostic select

AVAILABLE SOON

0:	FsD with longest run time	1:	Longest run time	Output value:
2:	FsD with longest stop time	3:	Longest stop time	
4:	Run/Stop times	11:	Total running times	FsD1:
10:		17:	times	number
		24:	of starts	FsD7:

DIAGNOSTICS  
SC DIAGNOSTIC

**POWER SECTION**

**Power connections**

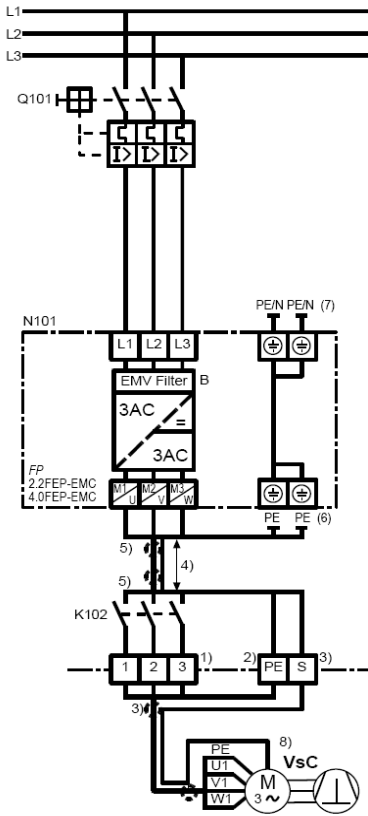

**FP 4.0FEP / iS RCF9.5:**  
Power wiring

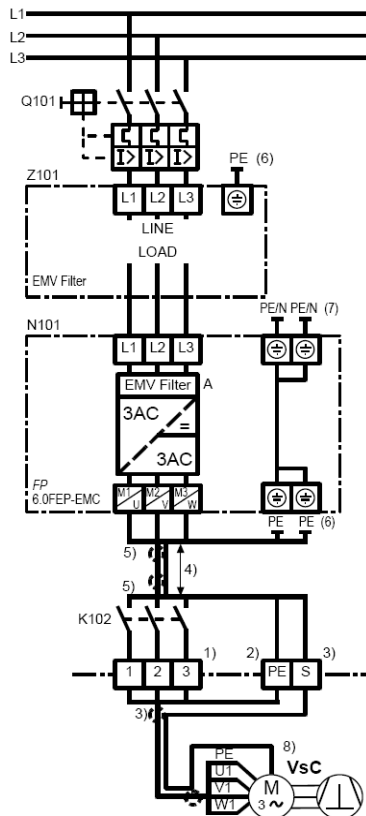

**FP 6.0FEP / iS RCF14:**  
Power wiring

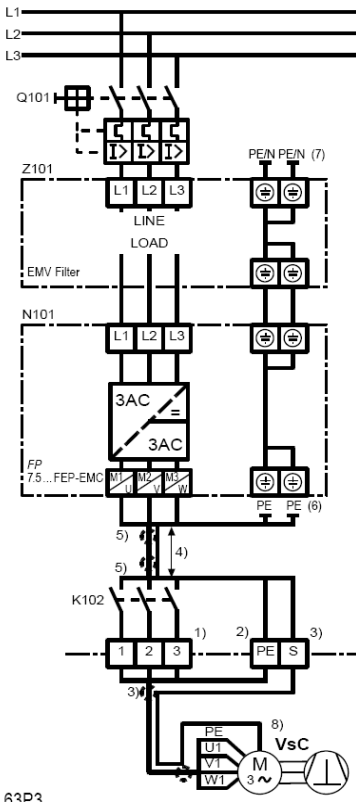

**FP 7.5 ... 90FEP / iS RCF23 ... 205:**  
Power wiring

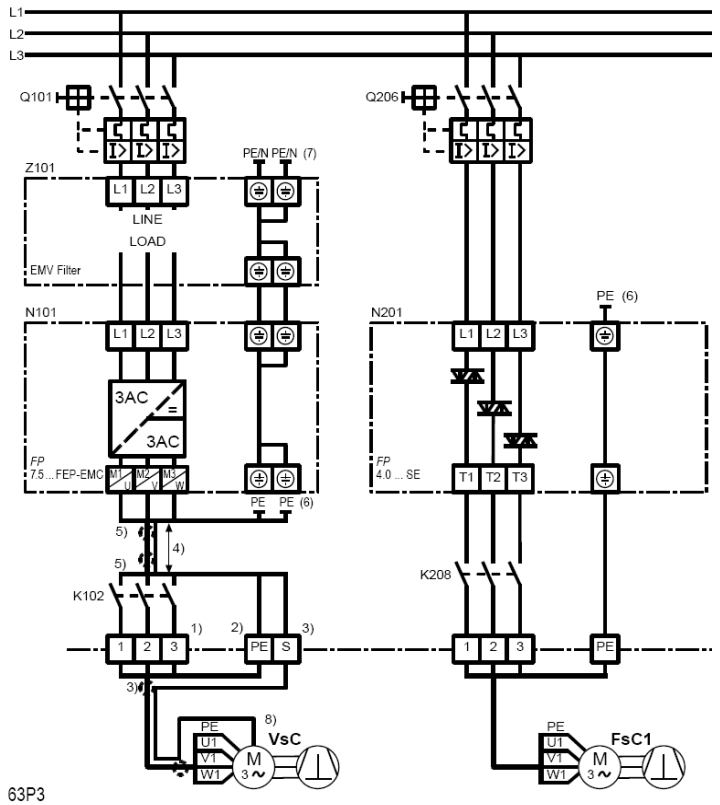

**FP 7.5 ... 90FEP / iS RCF23 ... 205:**  
Power wiring with two compressors

### Power terminals

Terminal / Designation	Signal / Function	Explanation	Further information
PE, PE	FP ...30FEP-EMC / iS RCF23 ... 73: Protective earth connections (both to be earthed)	- Observe all safety and EMC requirements	7.7.1
PE	FP 37... FEP-EMC / iS RCF87...: Protective earth connection		
L1 L2/N L3	Three phases of voltage supply	- Ensure that supply voltage agrees with data on FrigoPack / iSpeed name plate	7.7.1
DC+ (DBR) DC-		- Do not use otherwise risk of damage to FrigoPack / iSpeed	
M1/U M2/V M3/W	Compressor motor	- Variable-speed Compressor via safety contactor	7.7.1/ 7.7.2
PE	Protective earth connection to compressor motor		7.7.2
(DBR+) (DBR-)		- Do not use otherwise risk of damage to FrigoPack / iSpeed	
AUX1 AUX2	Only with: FP 55...FEP-EMC / iS 2AC 230 supply for equipment fan	- Supply externally	6.7 6.8.4

### Terminals for motor protection

Terminal / Designation	Signal / Function	Explanation	Further information
<b>X2:</b>			
MOT/ TEMP	Alternative a), Without processing:	- Thermistor protection is processed in safety circuit, these two terminals must be linked	6.2
	Alternative b), Direct processing of motor thermistors:	- Connect motor thermistors between these two terminals	
	Alternative c), Processing an external thermistor relay:	- Connect the "normally open" contacts of external thermistor relay (e.g. KRIWAN) between these two terminals	
	Alternative d), Processing an external thermistor relay:	- Connect the "Normally open" contacts of an auxiliary relay wired to an external thermistor relay (e.g. KRIWAN) between these two terminals.	

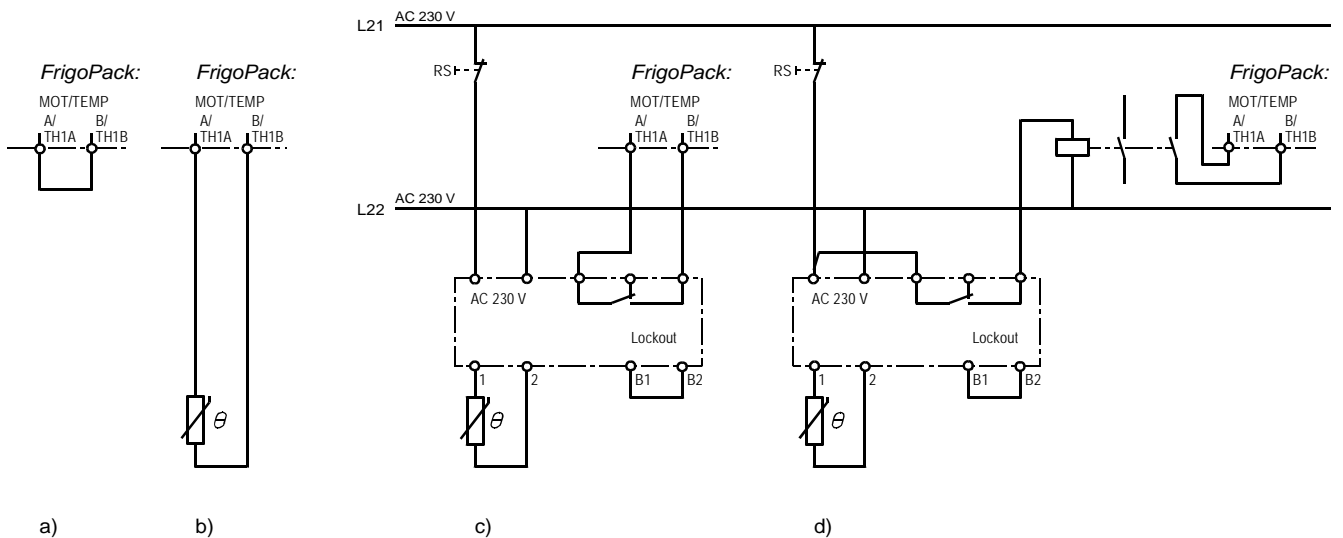

**CONTROL SECTION**

**Control connections**

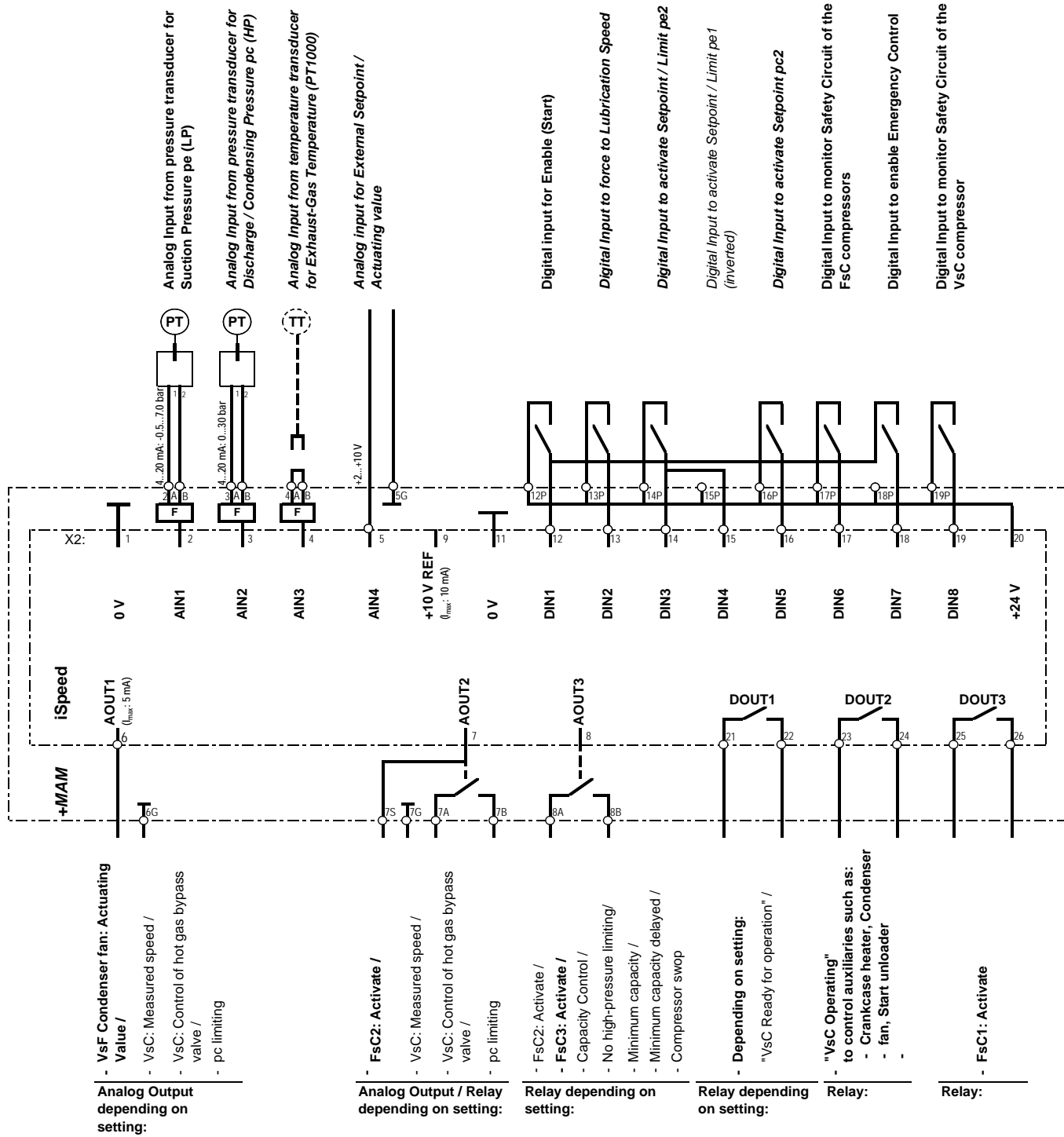

**A1:AOUT1 FUNCTN**

**A2:AOUT2 FUNCTN**

**A3:AOUT3 FUNCTN**

**A4:DOUT1 FUNCTN**

VsC: Variable-speed Compressor

FsC: Fixed-speed Compressor

FP FEP-14 / iSP RCF  
FrigoSoft 2.6

**Special settings**

**A1:AOUT1 FUNCTN**

Setting	Function
INPUT 0	VsF: Actuating Value
INPUT 1	VsC: Measured speed (Frequency)
INPUT 2	VsC: Control of hot gas bypass valve
INPUT 3	No high-pressure limiting

**A2:AOUT2 FUNCTN**

Setting	Function
INPUT 0	FsC2: Activate
INPUT 1	VsC: Measured speed (Frequency)
INPUT 2	VsC: Control of hot gas bypass valve
INPUT 3	No high-pressure limiting

**A3:AOUT3 FUNCTN**

Setting	Function
INPUT 0	FsC2: Activate
INPUT 1	FsC3: Activate
INPUT 2	Activate capacity control
INPUT 3	No high-pressure limiting
INPUT 4	Minimum capacity
INPUT 5	Minimum capacity delayed
INPUT 6	pe >= pemax
INPUT 7	General purpose swop signal

**A4:DOUT1 FUNCTN**

Refer to Page 10

AVAILABLE  
SOON



### Terminals for control functions

Terminal / Designation	Signal / Function	Explanation	Further information
2A - 2B	AIN1 Analog Input from pressure transducer for Suction Pressure $p_e$ (LP): 0 mA: Fault 4 mA: -0.5 bar 20 mA: +7.0 bar	- Suction pressure $p_e$ (LP), must be used - Suitable pressure transducer: - A REF-P-TRANSD-LP7+PL - Connections: - 1 --> 2A; 2 --> 2B	7.7.4
3A - 3B	AIN2 Analog Input from pressure transducer for Discharge / Condensing Pressure $p_c$ (HP): 0 mA: Not used 4 mA: 0.0 bar 20 mA: +30.0 bar	- Discharge / condens. pressure $p_c$ (HP), optional use - Suitable pressure transducer: - A REF-P-TRANSD-HP30+PL - Connections: - 1 --> 3A; 2 --> 3B	7.7.4
4A - 4B	AIN3 Analog Input from temperature transducer for Exhaust-Gas Temperature (PT1000)	- Exhaust-gas Temperature - Optional use - Bridge when not used	5.3, 7.7.5
5 - 5G	AIN4 Analog input for External Setpoint / Actuating value: 0 V: 0.0 % +10 V: 100.0 %	- External setpoint / actuating value required for operation with external controller - Use screened cable	5.2.3/4
6 - 6G	AOUT1 Analog Output (5 mA max. load): 0 V: 0.00 % Actuating value +10 V: 100.00 % Actuating value  Digital Output with ext. special relay: Open: Not activated Closed: Activated	- Depending on setting: <b>A1 : AOUT1 FUNCTN</b> - 0: VsF Condenser fan: Actuating Value / - 1: VsC: Measured speed / - 2: VsC: Control of hot gas bypass valve / - 3: $p_c$ limiting - Only use special relay A RELAY-DC12V (available as accessory)	7.7.3
7A - 7B	AOUT2 Analog Output (5 mA max. load) normally used with internal relay: 0 V: 0.00 % Actuating value +10 V: 100.00 % Actuating value  Digital Output with integrated relay: Open: Not activated Closed: Activated	- Depending on setting: <b>A2 : AOUT2 FUNCTN</b> - 0: FSC2: Activate / - 1: VsC: Measured speed / - 2: VsC: Control of hot gas bypass valve / - 3: $p_c$ limiting  - Max contact load: AC 230 V, 250 VA	7.7.3
8A - 8B	AOUT3 Analog Output used with internal relay:  Open: Not activated Closed: Activated  <b>AVAILABLE SOON</b>	- Depending on setting: <b>A3 : AOUT3 FUNCTN</b> - 0: FSC2: Activate / - 1: FSC3: Activate / - 2: Capacity Control / - 3: No high-pressure limiting/ - 4: Minimum capacity / - 5: Minimum capacity delayed / - 6: $p_e > p_{emax}$ / - 7: Compressor swop - Max contact load: AC 230; 250 VA	7.7.3
12P - 12	DIN1 Digital input for Enable (Start): 0 V: Stop +24 V: Enable	- Enable / Start	5.2.1-4, 7.7.3
13P - 13	DIN2 Digital Input to force to Lubrication Speed: 0 V: Normal +24 V: Lubrication speed	- Force Lubrication Speed - Optional use  - Requires external timer	5.3, 7.7.3
14P - 14	DIN3 Digital Input to activate Setpoint / Limit $p_{e2}$ : 0 V: No action +24 V: Activate Setpoint / Limit Value $p_{e2}$	- Setpoint / Limit selection $p_e$ - Optional use - Connect to DIN4 for normal selection	5.2.2/4, 7.7.3
15P - 15	DIN4 Digital Input to activate Setpoint / Limit $p_{e1}$ (inverted): 0 V: Activate Setpoint / Limit Value $p_{e1}$ +24 V: No action	- Setpoint / Limit selection (inverted) $p_e$ - Optional use - Connect to DIN3 for normal selection	5.2.2/4, 7.7.3
16P - 16	DIN5 Digital Input to activate Setpoint $p_{c2}$ : 0 V: No action +24 V: Activate Setpoint / Limit Value $p_{c2}$	- $p_c$ Setpoint selection - Optional use	5.3, 7.7.3
17P - 17	DIN6 Digital Input to monitor Safety Circuit of the FSC compressors: 0 V: $\geq 1$ FSCs not available or faulty +24 V: All FSCs available and fault free	- FSC Safety circuits without fault (Enables swop logic if all FSCs are available) - Alternative use: VSC continuous operation	5.3, 7.7.3
18P - 18	DIN7 Digital Input to enable Emergency Control: 0 V: No Emergency Control +24 V: Activate Emergency Control	- Emergency operation (Operation with a defect inverter or compressor) - Optional use	5.3, 7.7.3
19P - 19	DIN8 Digital Input to monitor Safety Circuit of the VsC compressor: 0 V: External fault +24 V: Normal (no fault)	- VsC Safety circuit without fault - Must be used - Interrupt if there is a fault (Required to stop inverter operation)	5.4, 7.7.3

Terminal / Designation	Signal / Function	Explanation	Further information
21 - 22	<b>DOUT1</b>  Relay output "VsC Ready": Open: <b>No supply, fault or alarm</b> Closed: <b>Ready (no fault)</b>  Optional additional functions with multiplex:  Relay "Ready+Multiplex": Open: <b>No supply, fault or alarm</b> Closed: <b>VsC Ready OR (VsC Operating AND Multiplexed Signal)</b>  Enable multiplex: <b>DATA 1 LOGIC 3: FALSE</b>	- "VsC Ready for operation" / Depending on setting: <b>A4 : DOUT1 FUNCTN</b> - 0: FsC3: Activate / - 1: FsC4: Activate / - 2: Minimum capacity / - 3: No high-pressure limiting/ - 4: Minimum capacity / - 5: Minimum capacity delayed / - 6: pe>=pemax/ - 7: Compressor swop - Max contact load: AC 230 V, 250 VA	5.4, 7.7.3
23 - 24	<b>DOUT2</b>  Relay output "VsC operating":  Open: <b>VsC: Inhibited / Not operating</b> Closed: <b>VsC: Starting / Operating</b>	- "VsC Operating" to control auxiliaries such as: Crankcase heater, Condenser fan, Start unloader  - Max contact load: AC 230 V, 250 VA	5.4, 7.7.3
25 - 26	<b>DOUT3</b>  Relay output to activate FsC1: Open: <b>Not activated</b> Closed: <b>Activated</b>	- FsC1: Activate  - Max contact load: AC 230 V, 250 VA	7.7.3

VsC: Variable-speed Compressor (Inverter operation)  
FsC: Fixed-speed Compressor

VsF: Variable-speed fan (condenser)

## Safety and control circuits

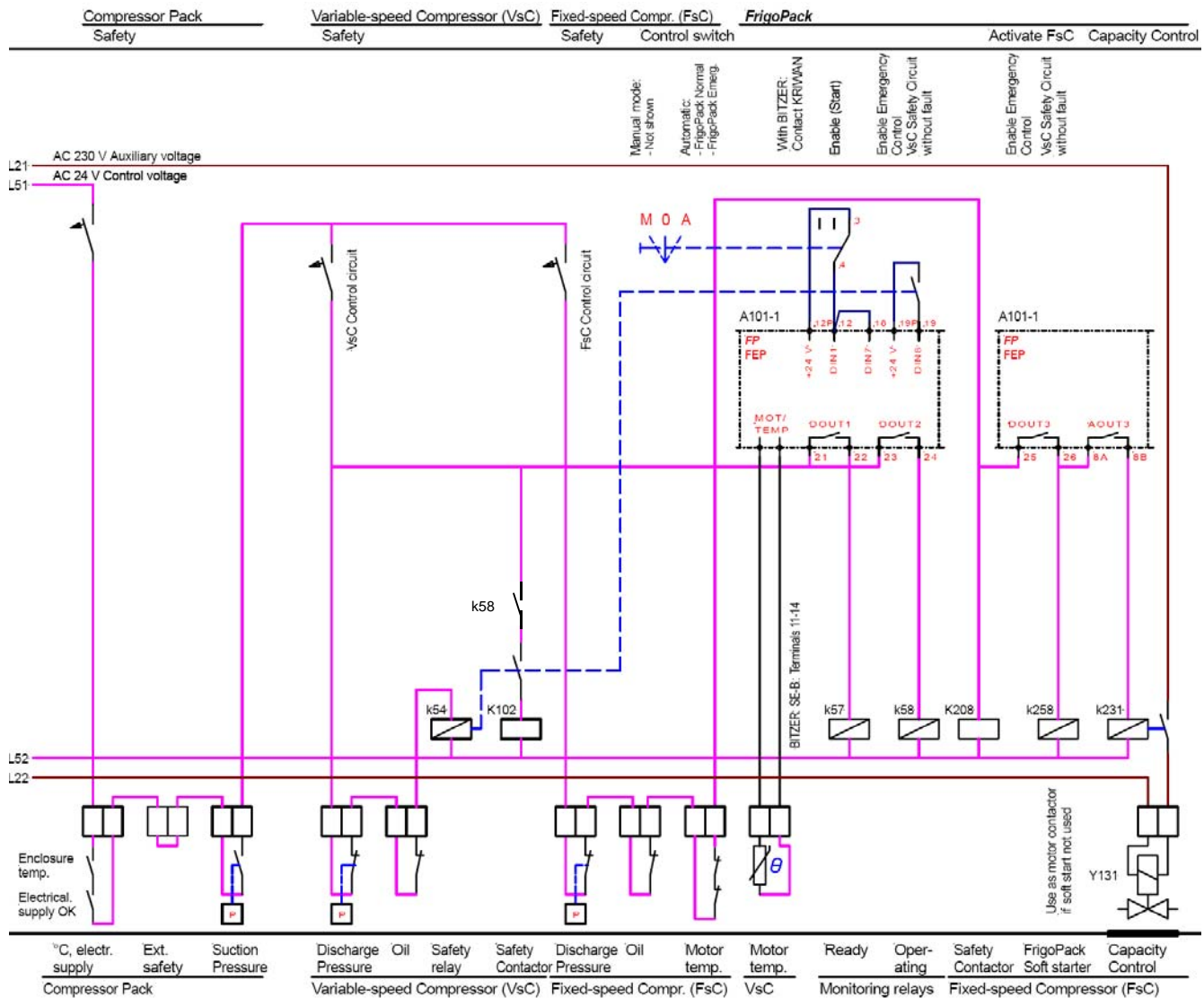

### Important note:

This simplified overview of the safety and control wiring of a typical system only includes the wiring for AUTOMATIC operation.

It is recommended that the following additional functions are included in the control system:

- MANUAL mode of operation using a "Pump Down" circuit
- A security circuit to provide:
  - Automatic selection of MANUAL operation in an emergency
  - Means of stopping the evaporators if compressors are not available.
- Standard suggestions for the safety and control wiring with these features are available on request.
- KIMO RHVAC can assist with the planning of complex systems or systems with special requirements.

## FIRST TIME POWER UP

<p><b>Electrical safety:</b></p> <p><b>UL compliance where appropriate:</b></p> <p><b>EMC compliance:</b></p> <p><b>Language selection:</b></p> <p><b>Selection of this refrigeration application, Restoring factory settings:</b></p>	<p>Ensure that all recommendations in the Product Manual have been adhered to</p> <p>Ensure that all recommendations in the Product Manual for UL compliance have been adhered to</p> <p>Ensure that all recommendations in the Product Manual for EMC compliance have been adhered to</p> <p>- Power up holding key 'PROG' depressed - Release key 'PROG' and press key 'M' - Arrow to left of second line should appear - Select required language with the arrow keys 'UP' / 'DOWN'</p> <p>- Press key 'E' 4x followed by key 'M' 2x - OPERATOR menu ist selected</p> <p>- Power up while holding arrow keys 'UP' and 'DOWN' depressed.</p> <p style="text-align: center;">RESTORE DEFAULTS   UP TO CONFIRM</p> <p>should be shown</p> <p>- Press arrow key 'UP' - A short moment later APPLICATION   NONE will be shown</p> <p>- Press key 'M' - Arrow to left of second line should appear - Select configuration: FrigoSoft26.2_1x with arrow keys 'UP'/'DOWN' - Press key 'E', wait a short moment, press key 'E' 2x and verify if correct configuration has been - Store loaded configuration as follows</p> <p>- Press key 'PROG' 3s long SAVE CONFIG   UP TO CONFIRM should be shown</p> <p>- Press arrow key 'UP' and wait until following message is shown in the second line: SAVING -&gt; COMPLETE</p> <p>- Press key 'E' 2x followed by key 'M' 2x - OPERATOR menu ist selected</p>						
<p><b>Storing configurations and parameter changes:</b></p>	<p>- Press key 'PROG' 3s long SAVE CONFIG   UP TO CONFIRM should be shown</p> <p>- Press arrow key 'UP' and wait until following message is shown in the second line: SAVING -&gt; COMPLETE</p> <p>- Press key 'E' 2x followed by key 'M' 2x - OPERATOR menu ist selected</p>						
<p><b>Pressure transducers:</b></p>	<p>This refrigeration application is designed for use with the following pressure transducers:</p> <table border="0"> <tr> <td>- pe: -0.5 ... 7.0 bar</td> <td>-7.25 ... 101.53 psi</td> <td>Relative (gauge) pressure</td> </tr> <tr> <td>- pc: 0 ... 30 bar</td> <td>0.00 ... 435.11 psi</td> <td>"</td> </tr> </table> <p><b>WARNING: Only use approved pressure transducers</b></p>	- pe: -0.5 ... 7.0 bar	-7.25 ... 101.53 psi	Relative (gauge) pressure	- pc: 0 ... 30 bar	0.00 ... 435.11 psi	"
- pe: -0.5 ... 7.0 bar	-7.25 ... 101.53 psi	Relative (gauge) pressure					
- pc: 0 ... 30 bar	0.00 ... 435.11 psi	"					

## OPERATING MODE

### A6: CONTRL FUNCTN

Setting	Function	Explanation	
- . . . X	Basic control method		
- . . . 0	Suction pressure control to setpoints pe1 / pe2 as selected by DIN3/DIN4 at terminals 14/15:	- pe1 as set by - pe2 as set by - Factory setting	31:pe SETPOINT 1 32:pe SETPOINT 2
- . . . 1	Suction pressure control to an external actuating value at AIN4 within the range +2...+10 V :	- AIN4 = 2 V: : - AIN4 = 10 V:	39:pe MAXIMUM : 31:pe SETPOINT 1/ 32:pe SETPOINT 2
- . . . 2	Suction pressure control to an external actuating value at AIN4 within the range +2...+10 V :	- AIN4 = 2 V: : - AIN4 = 10 V:	32:pe SETPOINT 2 : 31:pe SETPOINT 1
- . . . 3	Suction pressure control to a fixed test setpoint:	For test purposes	0.0 bar / 0.0 psig
- . . X.	Control of condenser		
- . . 0.	Condensing pressure control to setpoints pc1/pc2:	- pc1 as set by - pc2 as set by - Factory setting	41:pc SETPOINT 1 42:pc SETPOINT 2
- . . 1.	Condensing pressure control to an external actuating value	- AIN4 = 0 V: : - AIN4 = 10 V:	41:pc SETPOINT 1 : 42:pc SETPOINT 2
- . . 2.	Floating condensing pressure control	- Depending on ambient temperature	
- . . 3.	Condensing pressure control to a fixed test setpoint	- For test purposes corresponding to	55 °C / 131 °F

## TROUBLE SHOOTING LIST

PROBLEM	POSSIBLE CAUSE	Hints for fault finding	REMEDIES
<b>*** TRIPPED ***</b> <b>T01: OVERVOLTAGE</b>	<ul style="list-style-type: none"> <li>* Voltage of supply too high</li> <li>* Safety contactor not controlled correctly</li> <li>* Compressor motor defect</li> </ul>	<ul style="list-style-type: none"> <li>- Measure and document the voltage in all three input phases</li> <li>- Check wiring of control circuit and compare function with KIMO RHVAC recommendations</li> <li>- Test if compressor motor will run with DOL supply</li> <li>- Measure resistance of motor winding and compare with manufacturer's data</li> <li>- Check insulation between phases and to earth</li> </ul>	<ul style="list-style-type: none"> <li>- Rectify cause of any high voltage</li> <li>- Modify wiring</li> <li>- Replace compressor motor</li> </ul>
<b>*** TRIPPED ***</b> <b>T02: UNDERVOLTAGE</b>	<ul style="list-style-type: none"> <li>* Voltage of supply too low</li> </ul>	<ul style="list-style-type: none"> <li>- Measure and document the voltage in all three input phases</li> </ul>	<ul style="list-style-type: none"> <li>- Rectify cause of any low voltage</li> </ul>
<b>*** TRIPPED ***</b> <b>T03: OVERCURRENT</b>	<ul style="list-style-type: none"> <li>* Phase of supply voltage missing</li> </ul>	<ul style="list-style-type: none"> <li>- Check wiring of control circuit and compare function with KIMO RHVAC recommendations</li> <li>- Test if compressor motor will run with DOL supply</li> <li>- Measure resistance of motor winding and compare with manufacturer's data</li> <li>- Check insulation between phases and to earth</li> </ul>	<ul style="list-style-type: none"> <li>- Modify wiring</li> <li>- Replace compressor motor</li> </ul>
<b>*** TRIPPED ***</b> <b>T24: IGBT DESAT</b>	<ul style="list-style-type: none"> <li>* Safety contactor not controlled correctly</li> <li>* Compressor motor defect</li> <li>* Power section of FrigoPack / iSpeed faulty</li> <li>* Incorrect motor connection</li> </ul>	<ul style="list-style-type: none"> <li>- Check wiring of control circuit and compare function with KIMO RHVAC recommendations</li> <li>- Test if compressor motor will run with DOL supply</li> <li>- Measure resistance of motor winding and compare with manufacturer's data</li> <li>- Check insulation between phases and to earth</li> <li>- Remove motor cable connections to FrigoPack / iSpeed</li> <li>- Check if operation of FrigoPack / iSpeed without a motor connected is possible (No trip message: Probably OK; Trip message: Probably defect)</li> <li>- Test for operation with a small test motor</li> <li>- Check wiring to motor terminals (choice of star/delta, part winding etc.)</li> </ul>	<ul style="list-style-type: none"> <li>- Replace FrigoPack / iSpeed</li> <li>- Modify wiring</li> </ul>
<b>*** TRIPPED ***</b> <b>T05: SAFETY CIRCT</b>	<ul style="list-style-type: none"> <li>* Safety contactor not controlled correctly</li> <li>* Safety device in safety circuit tripped</li> <li>* DC 24 V control voltage missing</li> </ul>	<ul style="list-style-type: none"> <li>- Check wiring of control circuit and compare function with KIMO RHVAC recommendations</li> <li>- Check safety circuits</li> <li>- Check DC 24 V control voltage at FrigoPack / iSpeed</li> <li>- Short circuit with DC 24 V control voltage</li> </ul>	<ul style="list-style-type: none"> <li>- Modify wiring</li> <li>- Reset if necessary</li> <li>- Modify wiring</li> </ul>
<b>*** TRIPPED ***</b> <b>T06: AIN1 BREAK</b>	<ul style="list-style-type: none"> <li>* Suction-pressure transducer not connected or connections swapped</li> <li>* Transducer for suction pressure faulty</li> </ul>	<ul style="list-style-type: none"> <li>- Check if blue LED at the input of FrigoPack / iSpeed lights</li> <li>- Measure current from transducer for suction pressure at input to FrigoPack / iSpeed (must be at least +4 mA)</li> </ul>	<ul style="list-style-type: none"> <li>- Verify correct connection to transducer for suction pressure. Exchange leads if necessary</li> <li>- Replace transducer for suction pressure</li> </ul>
<b>*** TRIPPED ***</b> <b>T09: I*T LIMIT</b>	<ul style="list-style-type: none"> <li>* Compressor start aborted</li> </ul>	<ul style="list-style-type: none"> <li>- Liquid refrigerant in compressor?</li> <li>- Defect compressor</li> <li>- Unsuitable FrigoPack / iSpeed settings</li> </ul>	<ul style="list-style-type: none"> <li>- Contact KIMO RHVAC for advice</li> </ul>
<b>*** TRIPPED ***</b> <b>T17: MOT OVERTEMP</b>	<ul style="list-style-type: none"> <li>* Link TH1A-TH1B or MOT/TEMP missing</li> <li>* No connection to motor protection PTC</li> <li>* Faulty connection to external PTC relay</li> <li>* Motor winding too hot</li> </ul>	<ul style="list-style-type: none"> <li>- Check wiring of control circuit and compare function recommendations</li> <li>- Compressor overloaded</li> </ul>	<ul style="list-style-type: none"> <li>- Modify wiring</li> <li>- Contact KIMO RHVAC for advice</li> </ul>
<b>*** TRIPPED ***</b> <b>T28: AIN1/2 ERROR</b>	<ul style="list-style-type: none"> <li>* Transducer for pressure faulty</li> <li>* Non compatible type of pressure transducer</li> </ul>	<ul style="list-style-type: none"> <li>- Measure current from transducer at input to FrigoPack / iSpeed (must be between 4 .. 20 mA)</li> <li>- Check if type of pressure transducer is compatible by referring to Section 3.3 or 7.7.4 of the Product Manual</li> </ul>	<ul style="list-style-type: none"> <li>- Replace pressure transducer</li> <li>- Replace pressure transducer by compatible type</li> </ul>
<b>*** TRIPPED ***</b> <b>?ANYTHING ELSE?</b>	<ul style="list-style-type: none"> <li>* Anything else</li> </ul>		<ul style="list-style-type: none"> <li>- Contact KIMO RHVAC for advice</li> </ul>

**Important note:** These messages are of common trips likely to occur during commissioning. Other trip messages can occur in fault conditions.

When requesting advice from your supplier, always make an exact note of the following:

- Exact trip message in both lines of display
- Message displayed when key 'E' is pressed for at least 10 s.

**CHECKLIST AND ADDITIONAL DATA FOR PROBLEM REPORT**

KIMO Problem Code	Part of installation	Checklist of questions for PROBLEM REPORT	Explanation	Terminals	Answer/ Confirmation
ES	Electrical: - Supply	<ul style="list-style-type: none"> <li>Are there any known power supply interruptions ?</li> <li>Do these power supply interruptions occur at the same time each day ?</li> <li>By what amount does the supply voltage vary ?</li> </ul>	<ul style="list-style-type: none"> <li>- Indicate approx. times</li> <li>- Indicate min. and max. voltages</li> </ul>		Yes <input type="checkbox"/> No <input type="checkbox"/> Yes <input type="checkbox"/> No <input type="checkbox"/> When: _____ _____ Min.: _____ [V] Max.: _____ [V]
EI	- Installation	<ul style="list-style-type: none"> <li>Motor cable: Approx. Length ?</li> <li>Motor cable: Type of screen ?</li> <li>Motor cable: Screen connected to mounting plate?</li> <li>Motor cable: Screen connected to metal motor housing ?</li> <li>Is a galvanised mounting plate used in the electrical enclosure ?</li> <li>Is a motor filter used between the FrigoPack / iSpeed and the compressor motor ?</li> </ul>	<ul style="list-style-type: none"> <li>- Copper braid ?, Steel braid ?,</li> <li>- Steel conduit ?, none ?</li> <li>- Recommendations: - Contact with large surface area</li> <li>- Make sure no "pig tails"</li> <li>- If yes, indicate KIMO product code</li> </ul>		Cu brd. <input type="checkbox"/> Fe brd. <input type="checkbox"/> Fe cond. <input type="checkbox"/> None <input type="checkbox"/> Yes <input type="checkbox"/> No <input type="checkbox"/> Yes <input type="checkbox"/> No <input type="checkbox"/> Yes <input type="checkbox"/> No <input type="checkbox"/> Yes <input type="checkbox"/> No <input type="checkbox"/> Pr. Cde: _____
MT	Compressor motor	<ul style="list-style-type: none"> <li>Have motor currents been entered into the PROBLEM REPORT ?</li> </ul>	<ul style="list-style-type: none"> <li>- Operating point</li> <li>- Start up</li> </ul>		Yes <input type="checkbox"/> No <input type="checkbox"/> Yes <input type="checkbox"/> No <input type="checkbox"/>
MM MM CI	FrigoPack / iSpeed: - Control and sensor inputs	<ul style="list-style-type: none"> <li>Protective Earth of FrigoPack / iSpeed connected to mounting plate (two separate short connections) ?</li> <li>Is the DC P24 control voltage present ?</li> <li>Connection of PTC motor protection ?</li> <li>Safety circuit OK ?</li> <li>Enable signal present ?</li> <li>External setpoint or actuating signal present ? *</li> <li>Signal from suction-pressure transducer present ?</li> <li>Signal from high-pressure transducer present ? *</li> <li>Signal from exhaust temperature transducer present (link if not used) ? *</li> <li>* If used</li> </ul>	<ul style="list-style-type: none"> <li>- Without processing</li> <li>- Direct processing of motor thermistors</li> <li>- Processing an external thermistor relay</li> </ul>	Terminal: 2x PE  Terminal: 15P - GN  Terminal: MOT/TEMP  Terminals for measuring: 19 - GN Terminals for measuring: 12 - GN Terminals for measuring: 5 - GN Terminals for measuring: 2B - GN Terminals for measuring: 3B - GN Terminals for measuring: 4B - GN Terminals for measuring: 4A - 4B Terminal for measuring: .. Measured against green terminal: ..	Yes <input type="checkbox"/> No <input type="checkbox"/> Yes <input type="checkbox"/> No <input type="checkbox"/> Linked <input type="checkbox"/> Direkt <input type="checkbox"/> Relay <input type="checkbox"/> Yes <input type="checkbox"/> No <input type="checkbox"/> Yes <input type="checkbox"/> No <input type="checkbox"/> _____ [V] _____ [V] _____ [V] Yes <input type="checkbox"/> No <input type="checkbox"/>
MM	PS	- Power section	<ul style="list-style-type: none"> <li>Reserved for future use</li> </ul>		
MM	CA	- Control assembly	<ul style="list-style-type: none"> <li>Reserved for future use</li> </ul>		
MM	CS	- Control settings, parameter	<ul style="list-style-type: none"> <li>Operating Mode LOCAL (Programming Pad: LEDs SEQ + REF light) ?</li> <li>Refrigeration / cooling parameters set ?</li> </ul>	<ul style="list-style-type: none"> <li>- Not suitable for normal operation, only use for commissioning:</li> <li>- The following parameters must be set: <b>30: ... 50:</b></li> </ul>	Yes <input type="checkbox"/> No <input type="checkbox"/> Yes <input type="checkbox"/> No <input type="checkbox"/> Yes <input type="checkbox"/> No <input type="checkbox"/>
RI	AP	Refrigeration: - Application	<ul style="list-style-type: none"> <li>Required Refrigeration Power entered into PROBLEM REPORT ?</li> <li>Number of cooling outputs entered into the PROBLEM REPORT ?</li> <li>Operating pressure and temperatures entered into PROBLEM REPORT ?</li> <li>On/Off times of compressor pack entered into PROBLEM REPORT ?</li> </ul>	<ul style="list-style-type: none"> <li>- Operating point</li> <li>- At start up</li> <li>- Enter variable and fixed speed compressor times separately</li> </ul>	Yes <input type="checkbox"/> No <input type="checkbox"/> Yes <input type="checkbox"/> No <input type="checkbox"/> Yes <input type="checkbox"/> No <input type="checkbox"/> Yes <input type="checkbox"/> No <input type="checkbox"/>
RI	IN	- Installation	<ul style="list-style-type: none"> <li>Reserved for future use</li> </ul>	- tbd	
RI	PS	- Pressure transducers	<ul style="list-style-type: none"> <li>Approx. cable length</li> <li>Type of screen</li> <li>Screen NOT connected at sensor end ?</li> <li>Screen connected to mounting plate of electrical enclosure ?</li> <li>Are measured pressures stable ?</li> </ul>	<ul style="list-style-type: none"> <li>- Copper braid ?, Steel braid ?,</li> <li>- Steel conduit ?, none ?</li> <li>- Large area contact, no pig tails</li> <li>- Indicate range of variation within 30 s</li> </ul>	_____ [m] Cu brd. <input type="checkbox"/> Fe brd. <input type="checkbox"/> Fe cond. <input type="checkbox"/> None <input type="checkbox"/> Yes <input type="checkbox"/> No <input type="checkbox"/> Yes <input type="checkbox"/> No <input type="checkbox"/> Yes <input type="checkbox"/> No <input type="checkbox"/> pe/LP _____ pc/HP _____ [bar]
RI	RC	- Refrigeration compressor	<ul style="list-style-type: none"> <li>Oil present ?</li> <li>Basic data entered into PROBLEM REPORT ?</li> </ul>		Yes <input type="checkbox"/> No <input type="checkbox"/> Yes <input type="checkbox"/> No <input type="checkbox"/>

**CONFIGURATION OVERVIEW / PROBLEM REPORT**  
(Put cross in box where appropriate)

<b>Application</b>	Refrigeration <input type="checkbox"/>	No. of cooling outlets _____	Air Conditioning <input type="checkbox"/>	Condenser <input type="checkbox"/>	Other _____																																																																																													
<b>Refrigerant</b>	R404A..... <input type="checkbox"/>	R407C..... <input type="checkbox"/>	R134a..... <input type="checkbox"/>	Total refriger. Power _____ [kW]	Other _____																																																																																													
	R507A..... <input type="checkbox"/>	R22..... <input type="checkbox"/>	R..... <input type="checkbox"/>																																																																																															
<b>Compressor 1</b>	Piston <input type="checkbox"/>	No. of cylinders _____	Scroll <input type="checkbox"/>	Screw <input type="checkbox"/>	Other _____																																																																																													
	Start unloader <input type="checkbox"/>	Part Winding <input type="checkbox"/>	Variable speed <input type="checkbox"/>	<b>OR</b> Fixed speed <input type="checkbox"/>	No. of compressors _____																																																																																													
	Capacity control _____ [%]	_____ [%]	_____ [%]	_____ [%]																																																																																														
	Manufacturer _____	Model _____	Anything special _____																																																																																															
<b>Compressor 2</b>	Piston <input type="checkbox"/>	No. of cylinders _____	Scroll <input type="checkbox"/>	Screw <input type="checkbox"/>	Other _____																																																																																													
	Start unloader <input type="checkbox"/>	Part Winding <input type="checkbox"/>	Variable speed <input type="checkbox"/>	<b>OR</b> Fixed speed <input type="checkbox"/>	No. of compressors _____																																																																																													
	Capacity control _____ [%]	_____ [%]	_____ [%]	_____ [%]																																																																																														
	Manufacturer _____	Model _____	Anything special _____																																																																																															
<b>Operating point</b>	Suction pressure _____	High (discharge) pressure _____	Pascal/ <input type="checkbox"/>	Suction gas temperature _____ [°C]	Discharge gas temperature _____ [°C]																																																																																													
			bar/ <input type="checkbox"/>		Motor current _____ [A]																																																																																													
			lb/in <sup>2</sup> <input type="checkbox"/>																																																																																															
<b>Start up</b>	Suction pressure _____	High (discharge) pressure _____	gauge/ <input type="checkbox"/>	Anything special _____	Motor current _____ [A]																																																																																													
			absolute <input type="checkbox"/>																																																																																															
<b>Speed variator</b>	<b>FrigoPack/iSpeed/MotorMaster</b>		<b>Pressure sensors</b>		<b>FrigoSoft refrigeration/ A/C software</b> FS 2.6.2-2x																																																																																													
	Type FP/MM _____	Serial number _____	Suction pressure _____	Discharge pressure _____	Version _____																																																																																													
					Mode _____																																																																																													
<b>Soft Starter</b>	<b>FrigoPack/iSpeed/SoftCompact, LEKTROMIK</b>		<b>Switching times of compressor pack</b>																																																																																															
	Type FP/SC/LEK _____	Serial number _____	Variable-speed compressor (VsC) $t_{ON}$ _____ [s]	Fixed speed compressor(s) (FsCs) $t_{ON}$ _____ [s]	$t_{PERIOD}$ _____ [s]																																																																																													
					$t_{PERIOD}$ _____ [s]																																																																																													
<b>Report</b>	<p>List of adjustable parameters in OPERATOR menu</p> <table style="width:100%; border-collapse: collapse;"> <tr><td style="background-color: yellow;">30:pe MINIMUM</td><td style="background-color: yellow;">2.5 bar</td><td style="background-color: yellow;">_____ [bar]</td></tr> <tr><td style="background-color: yellow;">31:pe SETPOINT 1</td><td style="background-color: yellow;">3.3 bar</td><td style="background-color: yellow;">_____ [bar]</td></tr> <tr><td style="background-color: yellow;">32:pe SETPOINT 2</td><td style="background-color: yellow;">3.8 bar</td><td style="background-color: yellow;">_____ [bar]</td></tr> <tr><td style="background-color: yellow;">39:pe MAXIMUM</td><td style="background-color: yellow;">6.0 bar</td><td style="background-color: yellow;">_____ [bar]</td></tr> <tr><td style="background-color: yellow;">41:pc SETPOINT 1</td><td style="background-color: yellow;">17.3 bar</td><td style="background-color: yellow;">_____ [bar]</td></tr> <tr><td style="background-color: yellow;">42:pc SETPOINT 2</td><td style="background-color: yellow;">20.1 bar</td><td style="background-color: yellow;">_____ [bar]</td></tr> <tr><td style="background-color: yellow;">49:pc MAXIMUM</td><td style="background-color: yellow;">23.0 bar</td><td style="background-color: yellow;">_____ [bar]</td></tr> <tr><td style="background-color: yellow;">50:REFRIGERANT</td><td style="background-color: yellow;">R404A</td><td style="background-color: yellow;">_____</td></tr> <tr><td style="background-color: lightgreen;">61:VsC CURR MAX</td><td style="background-color: lightgreen;">FFF.FF A</td><td style="background-color: lightgreen;">_____ [Hz]</td></tr> <tr><td style="background-color: lightgreen;">62:VsC FREQ MAX</td><td style="background-color: lightgreen;">60.0 Hz</td><td style="background-color: lightgreen;">_____ [Hz]</td></tr> <tr><td style="background-color: lightgreen;">65:VsC FREQ MIN</td><td style="background-color: lightgreen;">25.0 Hz</td><td style="background-color: lightgreen;">_____ [Hz]</td></tr> <tr><td style="background-color: lightgreen;">66:VsC SKIP FREQ</td><td style="background-color: lightgreen;">0.0 Hz</td><td style="background-color: lightgreen;">_____ [%]</td></tr> <tr><td style="background-color: lightgreen;">67:VsC SKIP BAND</td><td style="background-color: lightgreen;">0.0 Hz</td><td style="background-color: lightgreen;">_____ [Hz]</td></tr> <tr><td style="background-color: lightgreen;">70:VsC tinh TIME</td><td style="background-color: lightgreen;">FFF.F s</td><td style="background-color: lightgreen;">_____ [s]</td></tr> <tr><td style="background-color: lightgreen;">71:VsC thld TIME</td><td style="background-color: lightgreen;">10.0 s</td><td style="background-color: lightgreen;">_____ [s]</td></tr> <tr><td style="background-color: lightblue;">74:VsC tmon fmin</td><td style="background-color: lightblue;">30.0 s</td><td style="background-color: lightblue;">_____ [s]</td></tr> <tr><td style="background-color: lightblue;">76:VsC toil STRT</td><td style="background-color: lightblue;">4.0 s</td><td style="background-color: lightblue;">_____ [s]</td></tr> <tr><td style="background-color: lightblue;">77:VsC poil MIN</td><td style="background-color: lightblue;">0.8 bar</td><td style="background-color: lightblue;">_____ [bar]</td></tr> <tr><td style="background-color: lightblue;">81:F sC ton DLY</td><td style="background-color: lightblue;">FFF s</td><td style="background-color: lightblue;">_____ [s]</td></tr> <tr><td style="background-color: lightblue;">82:F sC toff DLY</td><td style="background-color: lightblue;">FF s</td><td style="background-color: lightblue;">_____ [s]</td></tr> <tr><td style="background-color: lightblue;">83:F sC NUMBER</td><td style="background-color: lightblue;">1</td><td style="background-color: lightblue;">_____</td></tr> <tr><td style="background-color: purple;">91:pe CNTRL P-GN</td><td style="background-color: purple;">F.00</td><td style="background-color: purple;">_____</td></tr> <tr><td style="background-color: purple;">92:pc CNTRL P-GN</td><td style="background-color: purple;">10.00</td><td style="background-color: purple;">_____</td></tr> <tr><td style="background-color: purple;">93:VsF CD MIN SD</td><td style="background-color: purple;">15.00</td><td style="background-color: purple;">_____</td></tr> <tr><td style="background-color: purple;">94:pc LIMIT P-GN</td><td style="background-color: purple;">25.00</td><td style="background-color: purple;">_____</td></tr> <tr><td style="background-color: lightblue;">A1:AOUT1 FUNCTN</td><td style="background-color: lightblue;">INPUT 0</td><td style="background-color: lightblue;">_____</td></tr> <tr><td style="background-color: lightblue;">A2:AOUT2 FUNCTN</td><td style="background-color: lightblue;">INPUT 0</td><td style="background-color: lightblue;">_____</td></tr> <tr><td style="background-color: lightblue;">A3:AOUT3 FUNCTN</td><td style="background-color: lightblue;">INPUT 1</td><td style="background-color: lightblue;">_____</td></tr> <tr><td style="background-color: lightblue;">A4:DOUT1 FUNCTN</td><td style="background-color: lightblue;">INPUT 2</td><td style="background-color: lightblue;">_____</td></tr> <tr><td style="background-color: lightblue;">A6:CONTRL FUNCTN</td><td style="background-color: lightblue;">0000</td><td style="background-color: lightblue;">_____</td></tr> <tr><td style="background-color: lightblue;">A9:LANGUAGE</td><td style="background-color: lightblue;">ENGLISH</td><td style="background-color: lightblue;">_____</td></tr> </table>					30:pe MINIMUM	2.5 bar	_____ [bar]	31:pe SETPOINT 1	3.3 bar	_____ [bar]	32:pe SETPOINT 2	3.8 bar	_____ [bar]	39:pe MAXIMUM	6.0 bar	_____ [bar]	41:pc SETPOINT 1	17.3 bar	_____ [bar]	42:pc SETPOINT 2	20.1 bar	_____ [bar]	49:pc MAXIMUM	23.0 bar	_____ [bar]	50:REFRIGERANT	R404A	_____	61:VsC CURR MAX	FFF.FF A	_____ [Hz]	62:VsC FREQ MAX	60.0 Hz	_____ [Hz]	65:VsC FREQ MIN	25.0 Hz	_____ [Hz]	66:VsC SKIP FREQ	0.0 Hz	_____ [%]	67:VsC SKIP BAND	0.0 Hz	_____ [Hz]	70:VsC tinh TIME	FFF.F s	_____ [s]	71:VsC thld TIME	10.0 s	_____ [s]	74:VsC tmon fmin	30.0 s	_____ [s]	76:VsC toil STRT	4.0 s	_____ [s]	77:VsC poil MIN	0.8 bar	_____ [bar]	81:F sC ton DLY	FFF s	_____ [s]	82:F sC toff DLY	FF s	_____ [s]	83:F sC NUMBER	1	_____	91:pe CNTRL P-GN	F.00	_____	92:pc CNTRL P-GN	10.00	_____	93:VsF CD MIN SD	15.00	_____	94:pc LIMIT P-GN	25.00	_____	A1:AOUT1 FUNCTN	INPUT 0	_____	A2:AOUT2 FUNCTN	INPUT 0	_____	A3:AOUT3 FUNCTN	INPUT 1	_____	A4:DOUT1 FUNCTN	INPUT 2	_____	A6:CONTRL FUNCTN	0000	_____	A9:LANGUAGE	ENGLISH	_____
30:pe MINIMUM	2.5 bar	_____ [bar]																																																																																																
31:pe SETPOINT 1	3.3 bar	_____ [bar]																																																																																																
32:pe SETPOINT 2	3.8 bar	_____ [bar]																																																																																																
39:pe MAXIMUM	6.0 bar	_____ [bar]																																																																																																
41:pc SETPOINT 1	17.3 bar	_____ [bar]																																																																																																
42:pc SETPOINT 2	20.1 bar	_____ [bar]																																																																																																
49:pc MAXIMUM	23.0 bar	_____ [bar]																																																																																																
50:REFRIGERANT	R404A	_____																																																																																																
61:VsC CURR MAX	FFF.FF A	_____ [Hz]																																																																																																
62:VsC FREQ MAX	60.0 Hz	_____ [Hz]																																																																																																
65:VsC FREQ MIN	25.0 Hz	_____ [Hz]																																																																																																
66:VsC SKIP FREQ	0.0 Hz	_____ [%]																																																																																																
67:VsC SKIP BAND	0.0 Hz	_____ [Hz]																																																																																																
70:VsC tinh TIME	FFF.F s	_____ [s]																																																																																																
71:VsC thld TIME	10.0 s	_____ [s]																																																																																																
74:VsC tmon fmin	30.0 s	_____ [s]																																																																																																
76:VsC toil STRT	4.0 s	_____ [s]																																																																																																
77:VsC poil MIN	0.8 bar	_____ [bar]																																																																																																
81:F sC ton DLY	FFF s	_____ [s]																																																																																																
82:F sC toff DLY	FF s	_____ [s]																																																																																																
83:F sC NUMBER	1	_____																																																																																																
91:pe CNTRL P-GN	F.00	_____																																																																																																
92:pc CNTRL P-GN	10.00	_____																																																																																																
93:VsF CD MIN SD	15.00	_____																																																																																																
94:pc LIMIT P-GN	25.00	_____																																																																																																
A1:AOUT1 FUNCTN	INPUT 0	_____																																																																																																
A2:AOUT2 FUNCTN	INPUT 0	_____																																																																																																
A3:AOUT3 FUNCTN	INPUT 1	_____																																																																																																
A4:DOUT1 FUNCTN	INPUT 2	_____																																																																																																
A6:CONTRL FUNCTN	0000	_____																																																																																																
A9:LANGUAGE	ENGLISH	_____																																																																																																
<b>TRIP HISTORY</b>	TRIP TRIP TIME 1 _____	TRIP TRIP TIME 2 _____	TRIP TRIP TIME 3 _____	TRIP TRIP TIME 4 _____	TRIP TRIP TIME 5 _____																																																																																													
	(NEWEST)				(OLDEST)																																																																																													
	TRIP TRIP TIME 6 _____	TRIP TRIP TIME 7 _____	TRIP TRIP TIME 8 _____	TRIP TRIP TIME 9 _____	TRIP TRIP TIME 10 _____																																																																																													
					<b>TIME IN SERVICE</b> : _____ [s]																																																																																													
<b>Manufacturer</b>	<b>Agent / Partner</b>	<b>Customer</b>	<b>Installation</b>																																																																																															
KIMO Refrigeration HVAC Ltd EUR: Tel.: +49 911-8018778 Fax: +49 911-9976118 applications@frigokimo.com www.frigokimo.com																																																																																																		
Parker Hannifin Corporation Parker Hannifin Ltd: Tel.: +44 1226-273400 Fax: +44 1226-273401 eurocold@parker.com www.sporlan.com Sporlan Division: Tel.: +1 636-239-1111 Fax: +1 636-239-0414 svd_techsupport@parker.com www.sporlan.com																																																																																																		
			Name: _____	Date: _____																																																																																														