

FrigoPackE FMV

FPEI FMV/16
FrigoSoft E2

REFR/COOL

R134a MT All

PARAMETERS:

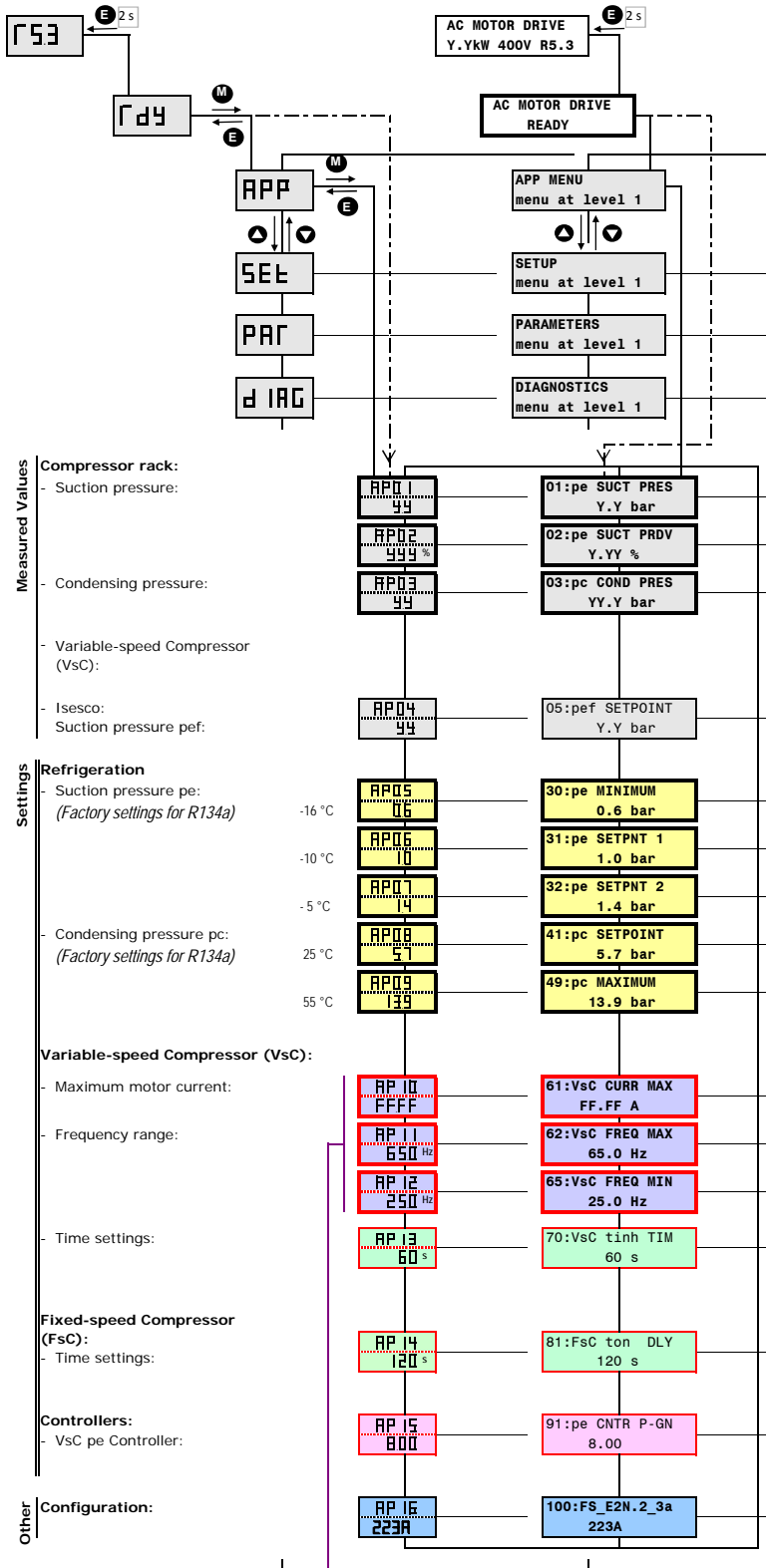

Type	Explanation	Further information
------	-------------	---------------------

See page 3
See page 3
See page 2

Automatic approx. 2 s after switching on

Measured value	pe, Suction pressure:	
. bar	- 0.5 ... 7.0 (bar)	
Deviation	pe, Suction pressure:	
. %	-100.0 ... 100.0 % (100.0 % ± 20.0 bar)	
Measured value	pc, Condensing pressure:	
. bar	0.0 ... 30.0 (bar)	

Motor frequency and current See page 2

Actuating value	pef, Floating setpoint (if Isesco in operation):	
. bar	- 0.5 ... 7.0 (bar)	

Limit value	pe, Stop value "Pump Down limit":	
. bar	- 0.0 ... 7.0 (bar)	
Setting	pe, Setpoint 1:	
. bar	- 0.0 ... 7.0 (bar)	
Setting	pe, Setpoint 2:	
. bar	- 0.0 ... 7.0 (bar)	
Setting	pc, Setpoint:	
. bar	0.0 ... 30.0 (bar)	
Limit value	pc, Limiting value:	
. bar	0.0 ... 30.0 (bar)	

See page 2
See page 2

Change these values if required

Password required (Please enquire)

Section in Product Manual

External keypad PROG1 required for this full display

Abbreviations:	
VsC:	Variable-speed Compressor
FsC:	Fixed-speed Compressor
VfG:	Variable-speed fan group (Condenser / Dry cooler)
YYY.Y %:	Measured value depending on operating point
FF.F %:	Factory default value depending on frame size and rated power

Standard refrigeration settings:
Based on EN 12900

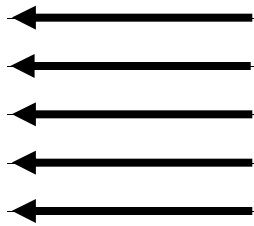

AP05 06	30:pe MINIMUM 0.6 bar
AP06 10	31:pe SETPNT 1 1.0 bar
AP07 14	32:pe SETPNT 2 1.4 bar
AP08 51	41:pc SETPOINT 5.7 bar
AP09 139	49:pc MAXIMUM 13.9 bar

Factory setting														
R134a			R404A / R507			R407F			R448A / N-40		R449A / XP40		R450A N13	
MT	IT	HT	LT	MT	IT	LT	MT	IT	LT	MT	IT	LT	MT	IT
-16	-5	1	-42	-16	-5	-42	-16	-5	-42	-16	-5	-42	-16	-5
0.6	1.4	2.0	0.2	2.5	4.1	-0.1	1.9	3.4	-0.1	1.9	3.4	-0.1	1.9	3.3
-10	0	5	-35	-10	0	-35	-10	0	-35	-10	0	-35	-10	0
1.0	1.9	2.5	0.6	3.3	5.0	0.3	2.6	4.2	0.3	2.7	4.2	0.3	2.6	4.1
-5	4	8	-29	-5	4	-29	-5	4	-29	-5	4	-29	-5	4
1.4	2.4	2.9	1.1	4.1	5.8	0.7	3.4	5.0	0.7	3.4	5.0	0.7	3.3	4.9
25			30			30			30			30		
5.7			13.3			14.0			13.8			13.5		
55			52			52			52			52		
13.9			23.2			24.4			24.0			23.6		

Refrigerant glide considered in these condensing pressures

Diagnostics

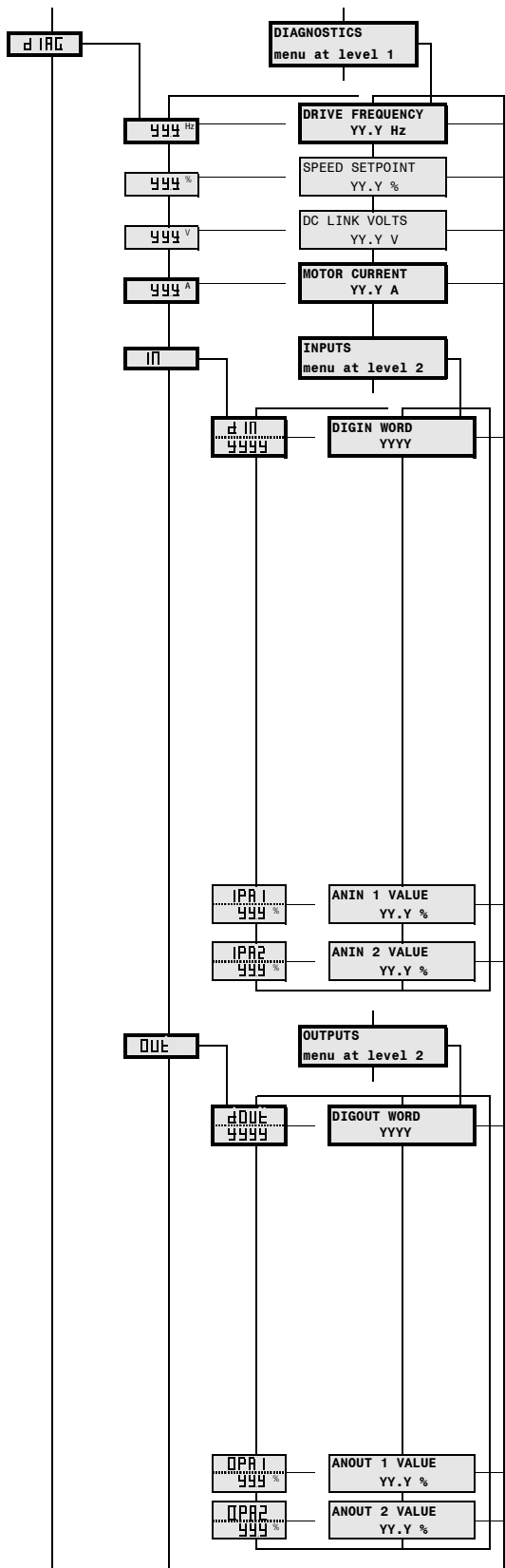

Measured value	Variable-speed Compressor: Motor frequency	
___ . __ Hz		

Measured value	VsC: Actuating value of Frequency: % of maximum frequency	
___ . __ %		

Measured value	DC link voltage	
___ . __ V		

Measured value	Variable-speed Compressor: Motor current	
___ . __ A		

Measured values	Inputs	
-----------------	--------	--

Measured values	Digital inputs:	
0000 ... 0073 (hex)		

4444	DIN7 [13]	DIN6 [12]	DIN5 [11]	DIN2 [8]	DIN1 [7]
00X0	X	X	X	0	0
00X1	X	X	X	0	1
00X2	X	X	X	1	0
00X3	X	X	X	1	1
000X	1	0	0	X	X
001X	1	0	1	X	X
002X	1	1	0	X	X
003X	1	1	1	X	X
004X	0	0	0	X	X
005X	0	0	1	X	X
006X	0	1	0	X	X
007X	0	1	1	X	X

Safety Circuit Activate Setp. pc2 Activate Setp. pe2 Lubric. f=50 Hz Start

Measured value	Analog input 1:	
___ . __ %	0.0 ... 100.0 (%)	

Measured value	Analog input 2:	
___ . __ %	0.0 ... 100.0 (%)	

Measured values	Outputs	
-----------------	---------	--

Measured values	Digital outputs:	
0000 ... 0006 (hex)		

0000	DOUT3 [RL1A-B]	DOUT2 [10A-10B]	DOUT1 [9A-9B]	Ready
0001	1	0	1	Operation VsC
0003	1	1	1	Operation VsC + FsC
0004	0	0	0	Trip
0006	0	1	0	Emergency operation FsC

VsC Ready Activate Fsc VsC in Operation

Measured value	Analog output 1: Condenser Fans:	
___ . __ %	0.0 ... 100.0 (%)	

Measured value	Analog output 2: 0...+10 V	
___ . __ %	0.0 ... 100.0 (%)	

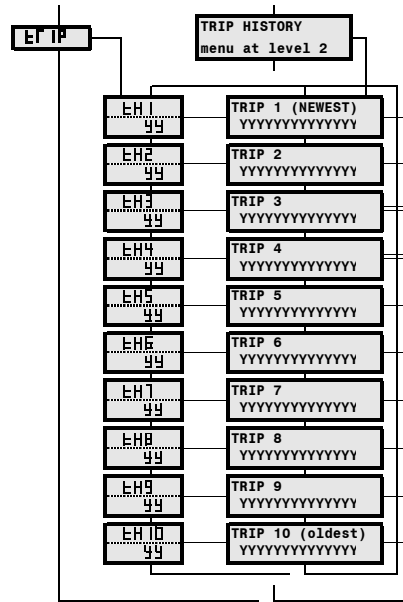

Trips	Trips history
Trips	Trips history
Trips	Trips history
Trips	Trips history
Trips	Trips history
Trips	Trips history
Trips	Trips history
Trips	Trips history
Trips	Trips history
Trips	Trips history
Trips	Trips history
Trips	Trips history
Trips	Trips history
Trips	Trips history
Trips	Trips history

4
5
6
7
8
9
10
11
12
13

- Trip code. Refer to page 4 for more details.**
- Code: 0 NO TRIP No trip
 - Code: 1 OVERVOLTAGE Overvoltage
 - Code: 2 UNDERVOLTAGE Undervoltage
 - Code: 3 OVERCURRENT Overcurrent
 - Code: 5 EXTERNAL TRIP Problem in Safety Circuit
 - Code: 6 INVERSE TIME Overload, start problem
 - Code: 7 CURRENT LOOP Current at AIN2 < 4 mA
 - Code: 17 MOTOR OVERTEMP PTC sensor indicates motor too hot
 - Code: 24 DESAT (OVER I) IGBT short circuit
 - Code: 25 DC LINK RIPPLE Too high ripple in DC link (missing phase?)
 - Code: 32 OTHER Other cause

Variable-speed Compressor (VsC)

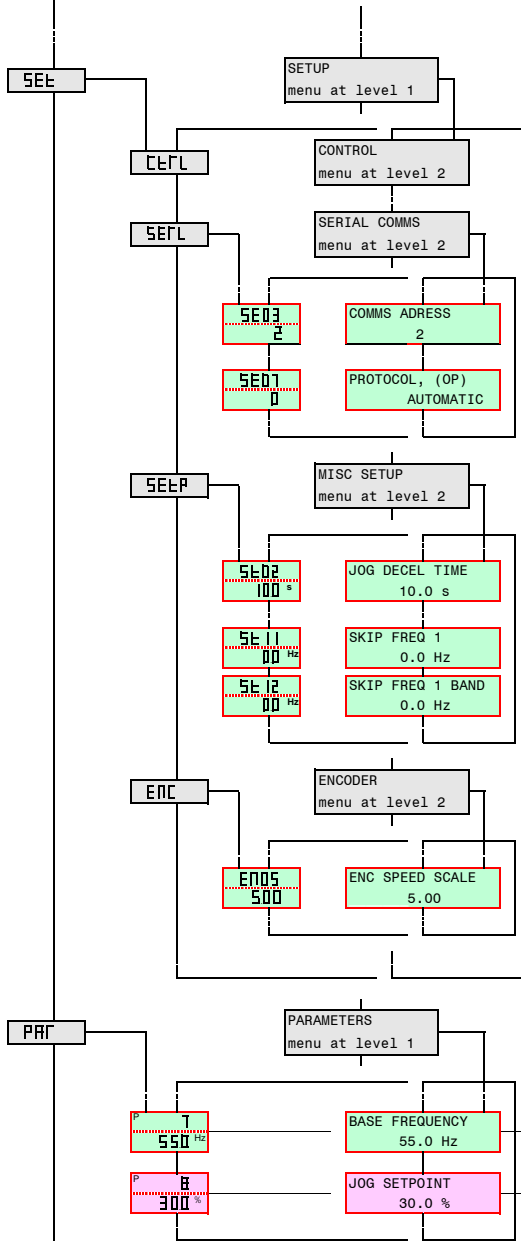

Communication:

- Modbus RTU, Address:

VfG pc Controllers:

Resonance avoidance:

Time settings:

Special settings:

- VfG Condenser fan:

Setting: Modbus RTU, Address:

Modify if required

Setting: Keypad mounting place:

0_AUTOMATIK / 3_MODBUS

Setting: pc controller, Proportional gain:

__ . __ s 0.1 ... 3000.0 (s)

Setting: VsC, Skip frequency:

__ . __ Hz 20.0 ... 120.0 Hz

Setting: VsC, Skip frequency band:

__ . __ Hz 0.0 ... 10.0 Hz

Setting: Oil-pulse time

__ . __ s 0.1 ... 3000.0 (s)

Setting: VsC: Motor base frequency

__ . __ Hz 20.0 ... 120.0 Hz

Setting: Condenser, VfG minimum speed:

__ . __ % 0.0 ... 50.0 %

Password required (Please enquire)

TRIPS, DIAGNOSIS, FAULT FINDING

TRIP MESSAGE	POSSIBLE CAUSE	HINTS FOR FAULT FINDING	REMEDIES
<p>*** TRIPPED *** OVERVOLTAGE</p> <p>↑ Code: 1 → DC HI</p> <p>(Code: See page 3)</p>	<ul style="list-style-type: none"> * Voltage of supply too high * Compressor motor defect * Safety contactor not controlled correctly 	<ul style="list-style-type: none"> - Measure and document the voltage in all three input phases - Test if compressor motor will run with DOL supply - Measure resistance of motor winding and compare with manufacturer's data - Check insulation between phases and to earth - Check wiring of control circuit and compare function with KIMO RHVACC recommendations 	<ul style="list-style-type: none"> - Rectify cause of any high voltage - Replace compressor motor - Modify wiring
<p>*** TRIPPED *** UNDervOLTAGE</p> <p>*** TRIPPED *** VDC RIPPLE</p> <p>*** TRIPPED *** DESAT (OVER I)</p> <p>*** TRIPPED *** OVERCURRENT</p> <p>↑ Code: 2 → DC LO</p> <p>↑ Code: 25 → DC RP</p> <p>↑ Code: 24 → SH FE</p> <p>↑ Code: 3 → OC</p> <p>(Code: See page 3)</p>	<ul style="list-style-type: none"> * Voltage of supply too low * Phase of supply voltage missing * Safety contactor not controlled correctly * Compressor motor defect * Power section of FrigoPack faulty * Incorrect motor connection 	<ul style="list-style-type: none"> - Measure resistance of motor winding and compare with manufacturer's data - Check wiring of control circuit and compare function with KIMO RHVACC recommendations - Test if compressor motor will run with DOL supply - Measure resistance of motor winding and compare with manufacturer's data - Check insulation between phases and to earth - Remove motor cable connections to FrigoPack / iSpeed - Check if operation of FrigoPack without a motor connected is possible (No trip message: Probably OK; Trip message: Probably defect) - Test operation with a small test motor - Check wiring to motor terminals (choice of star/delta, part winding etc.) 	<ul style="list-style-type: none"> - Rectify cause of any low voltage - Modify wiring - Replace compressor motor - Replace FrigoPack - Modify wiring
<p>*** TRIPPED *** EXTERNAL TRIP</p> <p>↑ Code: 5 → EE</p> <p>(Code: See page 3)</p>	<ul style="list-style-type: none"> * Safety contactor not controlled correctly * Safety device in safety circuit tripped * Wiring fault in safety circuit DC 24 V control voltage missing 	<ul style="list-style-type: none"> - Check wiring of control circuit and compare function with KIMO RHVACC recommendations - Check safety circuits. Possibly missing supply voltage at a monitoring device. - Check wiring of control circuit and compare function with KIMO RHVACC recommendations - Check DC 24 V control voltage at FrigoPack - Short circuit with DC 24 V control voltage ? 	<ul style="list-style-type: none"> - Modify wiring - Reset if necessary - Modify wiring - Modify wiring
<p>*** TRIPPED *** CURRENT LOOP</p> <p>↑ Code: 7 → LOOP</p> <p>(Code: See page 3)</p>	<ul style="list-style-type: none"> * Suction-pressure transducer not connected or connections swapped * Transducer for suction pressure faulty 	<ul style="list-style-type: none"> - Check if blue LED at the input of FrigoPack / iSpeed lights - Measure current from transducer for suction pressure at input to FrigoPack (must be at least +4 mA) 	<ul style="list-style-type: none"> - Verify correct connection to transducer for suction pressure. Exchange leads if necessary - Replace transducer for suction pressure
<p>*** TRIPPED *** INVERSE TIME</p> <p>↑ Code: 6 → IE</p> <p>(Code: See page 3)</p>	<ul style="list-style-type: none"> * Compressor start aborted 	<ul style="list-style-type: none"> - Liquid refrigerant in compressor? - Defect compressor - Incorrect size of FrigoPack or motor connected in delta instead of star. 	<ul style="list-style-type: none"> - Contact KIMO RHVACC for advice
<p>*** TRIPPED *** MOTOR OVERTEMP</p> <p>↑ Code: 17 → OT</p> <p>(Code: See page 3)</p>	<ul style="list-style-type: none"> * Missing link TH1A-TH1B or MOT/TEMP ? * No connection to motor protection PTC * Faulty connection to external PTC relay * Motor winding too hot 	<ul style="list-style-type: none"> - Check wiring of motor protection circuit - Compressor overloaded - Unsuitable FrigoPack settings 	<ul style="list-style-type: none"> - Modify wiring - Contact KIMO RHVACC for advice
<p>*** TRIPPED *** ?ANYTHING ELSE?</p>	<ul style="list-style-type: none"> * Other 		<ul style="list-style-type: none"> - Contact KIMO RHVACC for advice

Important note:

These messages are of common trips likely to occur during commissioning.

Other trip messages can occur in fault conditions.

When requesting advice from your supplier, always make an exact note of the following:

- Exact trip message (if appropriate message indicated in both lines of display)
- Message displayed when key 'E' is pressed for at least 2 s.

Cannot find fault ? ?:

Note the following parameters and send to KIMO RHVACC:

- Parameters AP01 ... AP16 on Page 1:
- Following settings on pages 1 ... 3:

1 ... 13

Manufacturer	Agent / Partner	Customer	Installation	
KIMO Refrigeration HVAC Ltd Tel.: +49 911-8018778 Fax: +49 911-9976118 applications@frigokimo.com www.frigokimo.com				
			Name	Date

POWER SECTION

Power connections

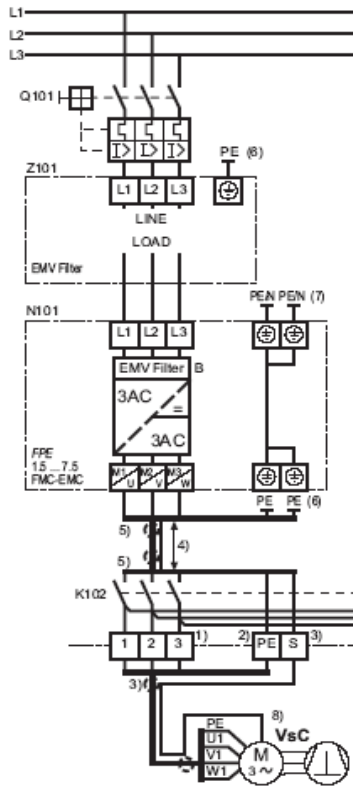

FPE FMV / FPEI FMV
Power wiring (basic connection)

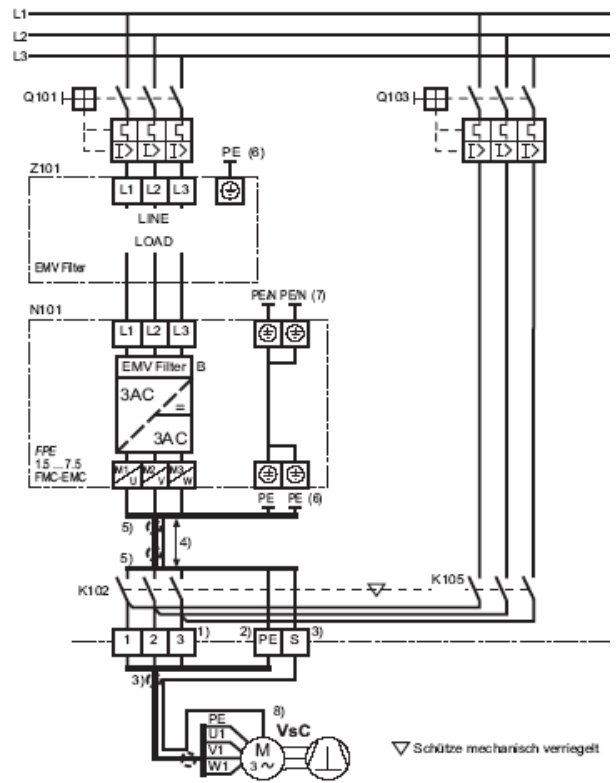

FPE FMV / FPEI FMV
Power wiring with bypass for emergency operation (recommended)

POWER SECTION

▽ Schütze mechanisch verriegelt

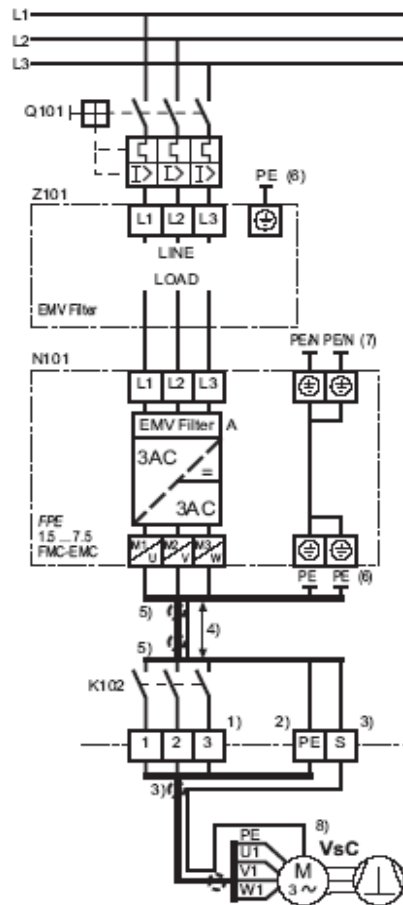

FPE FMV / FPEI FMV
Power wiring with bypass for emergency operation using a soft starter for bypass (recommended)

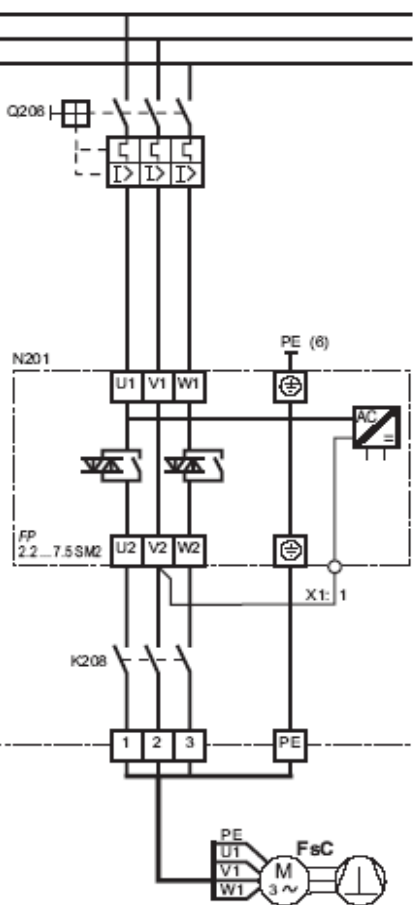

Power terminals

Terminal / Designation	Signal / Function	Explanation	Further information
PE	Protective Earth connection 1 to supply	- Observe all safety and EMC requirements	7.7.1
L1	Three phases of voltage supply	- Ensure that supply voltage agrees with data on FrigoPack name plate	7.7.1
L2/N			
L3			
PE	Protective Earth connection 2 to supply (both to be connected)	- Left-hand screw of cable clamp - Observe all safety and EMC requirements	6.7 6.8.4
DC+	Do not use	- Risk of damage to FrigoPack	
(DBR)			
DC-			
M1/U	Compressor motor	- Variable-speed Compressor via safety contactor	7.7.1/ 7.7.2
M2/V			
M3/W			
PE	Protective earth connection to compressor motor		7.7.2

Terminals for motor protection

Terminal / Designation	Signal / Function	Explanation	Further information
X2:			
TH1A - TH1B	Alternative a), Without processing:	- Thermistor protection is processed in safety circuit, these two terminals must be linked	6.2
	Alternative b), Direct processing of motor thermistors:	- Connect motor thermistors between these two terminals	
	Alternative b), Processing an external thermistor relay:	- Connect the "normally open" contacts of external thermistor relay (e.g. KRIWAN) between these two terminals	
	Alternative b), Processing an external thermistor relay:	- Connect the "Normally open" contacts of an auxiliary relay wired to an external thermistor relay (e.g. KRIWAN) between these two terminals.	

Alternative methods of motor protection

The terminals for the connections to the thermistor motor protection are situated above the power terminals

CONTROL SECTION: FrigoPacke FMV

Control connections

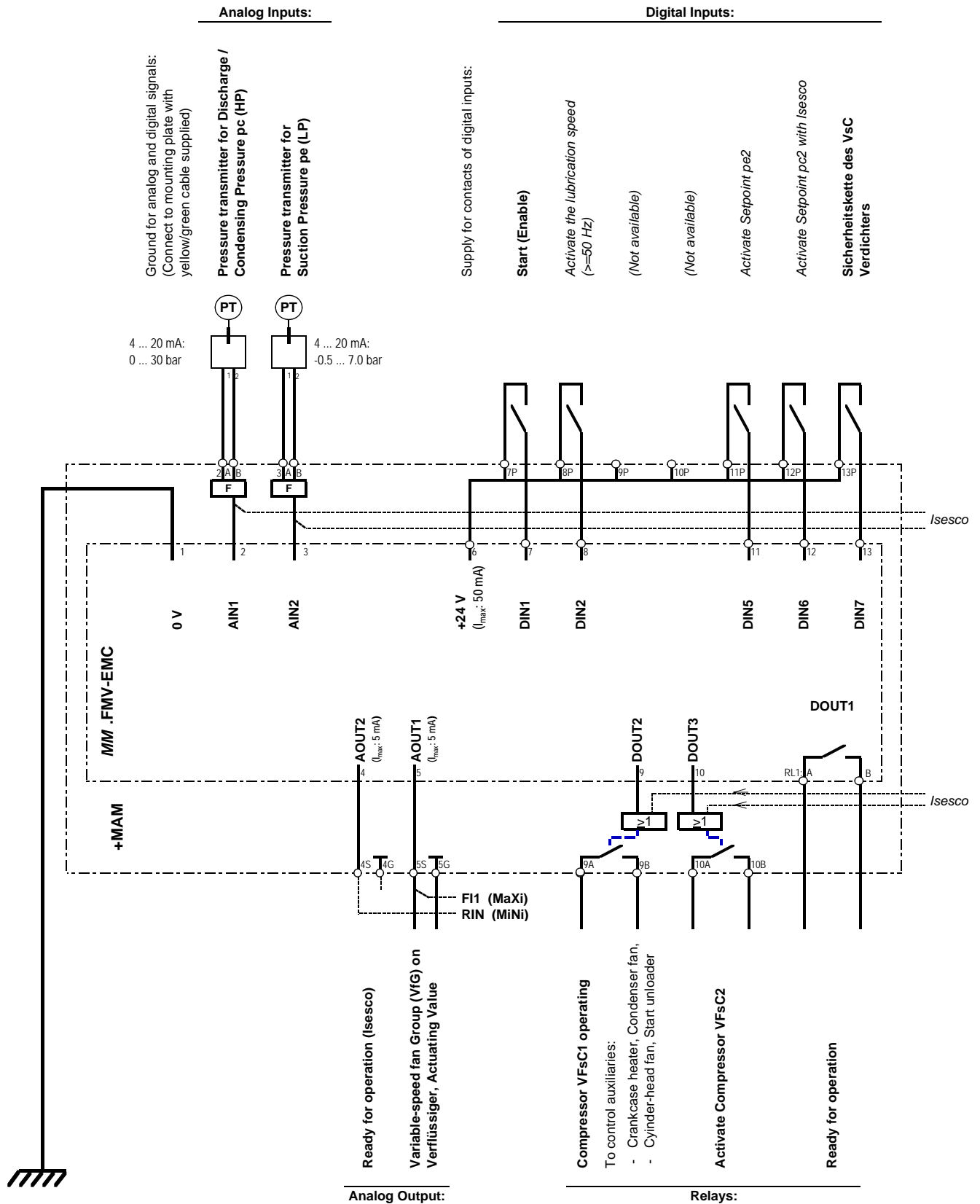

CONTROL SECTION

VFsc: Variable-speed Compressor

VfG: Variable-speed fan group (Condenser / Dry cooler)

Terminals for control functions

Terminal / Designation	Signal / Function	Explanation	Further information
FPE FMV:			
7	DIN1	Digital Input: Start (Enable) +24 V: Start 0 V: Controlled stop	- Must be used:
8	DIN2	<i>Digital Input:</i> <i>Activate Lubrication Speed (>=50 Hz)</i> +24 V: Lubrication speed 0 V: Normal operation	- <i>Optional use</i> - <i>Requires external timer</i>
11	DIN5	<i>Digital Input:</i> <i>Activate Setpoint pe2</i> +24 V: Setpoint pe2 0 V: No action	- <i>Optional use</i>
12	DIN6	<i>Digital Input:</i> <i>Activate Setpoint pc2</i> +24 V: Setpoint pc2 0 V: No action	- <i>Optional use</i>
13	DIN7	Digital Input: Safety Circuit of the VsC compressor +24 V: Fault free (normal operation) 0 V: Fault (immediate stop)	- Must be used - Interrupt if there is a fault - (Required to stop inverter operation immediately)
RL 1A - RL 1B	DOU3	Relay Output: "Ready" (without fault) Closed: Ready (no fault) Open: No supply, fault or alarm	- Max load: AC 230 V / 250 VA
MM O-FMV-MAM:			
1	0 V	Ground for analog signals	
2A - 2B	AIN1	Analog Input: Pressure transmitter for Discharge / Condensing 20 mA: +30.0 bar 4 mA: 0.0 bar 0 mA: Fault	- <i>Optional use</i> - Suitable pressure transducer: - A REFR-P-TRANSD-HP30+PL - Connections: - 1 --> 2A; 2 --> 2B
3A - 3B	AIN2	Analog Input: Pressure transmitter for Suction Pressure pe (LP) 20 mA: +7.0 bar 4 mA: -0.5 bar 0 mA: Fault	- Must be used - Suitable pressure transducer: - A REF-P-TRANSD-LP7+PL - Connections: - 1 --> 3A; 2 --> 3B
4S - 4G	AOUT2	Analog Output: Internal +10 V reference	- Do not use
5S - 5G	AOUT1	Analog Output: VfG Condenser fan, actuating value +10 V: 100.00 % 0 V: 0.00 %	- Max load: AC 230 V / 250 VA
9A - 9B	DOU1	Relay Output: "Operating" Closed: Starting / Operating Open: Inhibited / Not operating	- To control auxiliaries such as: - Crankcase heater - Condenser fan - Start unloader - Max load: AC 230 V / 250 VA
10A - 10B	DOU2	Relay Output: Activate CC Closed: Activate CC Open: Deactivate	- Max load: AC 230 V / 250 VA
7P ... 13P	P24	Supply for contacts of digital inputs:	- Max load: 10 mA

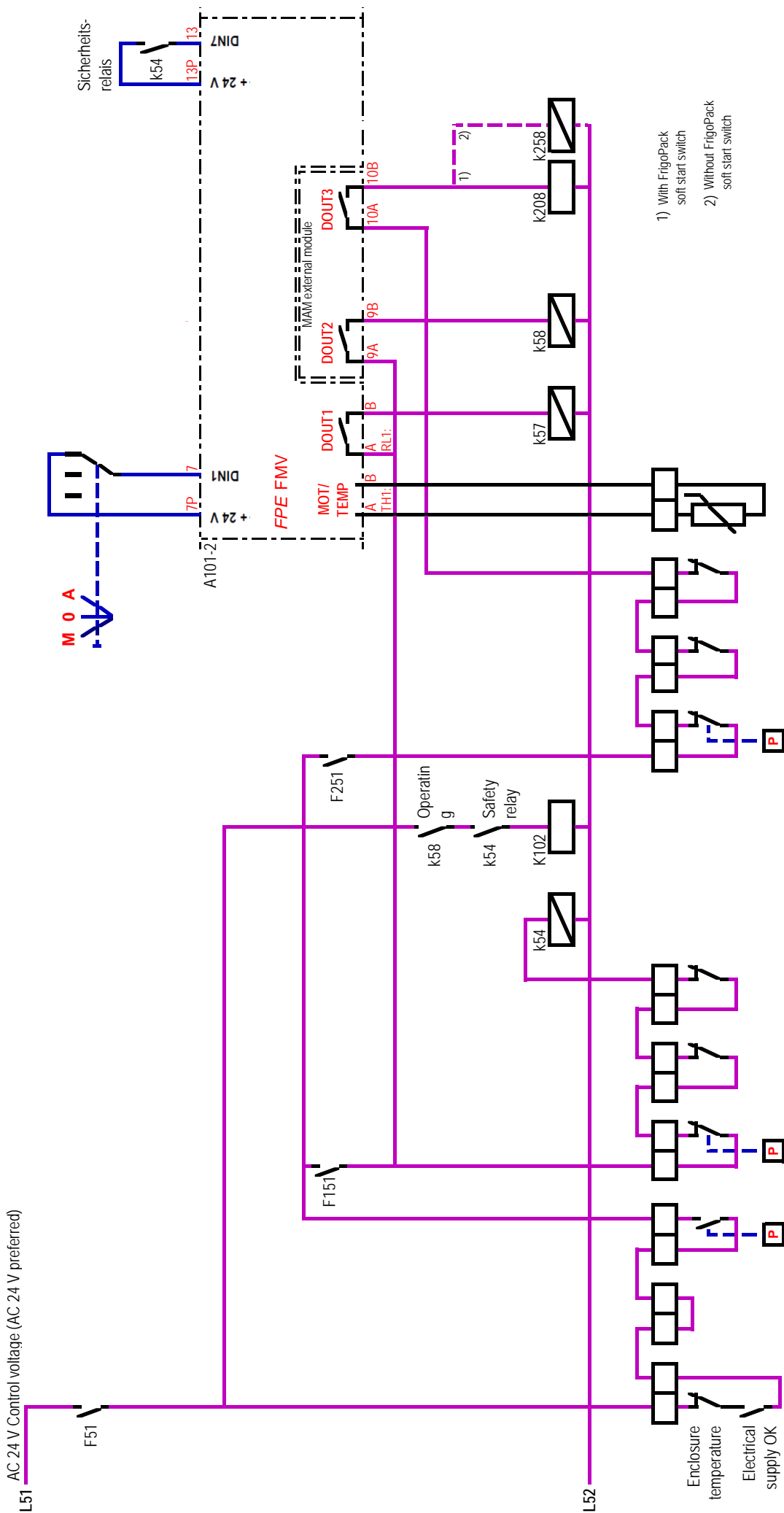

Component	Variable-speed Compressor 1 (VFSC1)	Fixed-speed Compressor 2 (VFC2)	Variable-speed Compressor 1 (VFSC1)	Fixed-speed Compressor 2 (VFC2)	Variable-speed Compressor 1 (VFSC1)	Fixed-speed Compressor 2 (VFC2)
High pressure	High pressure	High pressure	High pressure	High pressure	High pressure	High pressure
Lubrication	Lubrication	Lubrication	Lubrication	Lubrication	Lubrication	Lubrication
Motor temperature	Motor temperature	Motor temperature	Motor temperature	Motor temperature	Motor temperature	Motor temperature
Safety relay	Safety relay	Safety relay	Safety relay	Safety relay	Safety relay	Safety relay
Operating contact	Operating contact	Operating contact	Operating contact	Operating contact	Operating contact	Operating contact
Relay	Relay	Relay	Relay	Relay	Relay	Relay
Motor Contactor	Motor Contactor	Motor Contactor	Motor Contactor	Motor Contactor	Motor Contactor	Motor Contactor
Operation:	Variable-speed Compressor 1 (VFSC1)	Fixed-speed Compressor 2 (VFC2)	Variable-speed Compressor 1 (VFSC1)	Fixed-speed Compressor 2 (VFC2)	Variable-speed Compressor 1 (VFSC1)	Fixed-speed Compressor 2 (VFC2)

CONTROL SECTION

FIRST-TIME POWER UP

Mounting and electrical safety:

Ensure that all recommendations in the Product Manual have been adhered to.

UL compliance where appropriate:

Ensure that all recommendations in the Product Manual for UL compliance have been adhered to.

EMC compliance:

Ensure that all recommendations in the Product Manual for EMC compliance have been adhered to.

Language selection:

The language is only relevant when the two-line keypad from the FP(E) FEP ranges are used for commissioning.

Selection of this refrigeration application:

This refrigeration application is programmed in the refrigeration application software and can only be changed in the factory.

Storing configurations and parameter changes:

Storing parameter changes is automatic.

Pressure transducers:

This refrigeration application is designed for use with the following pressure transducers.

- pe: -0.5 ... 7.0 bar	-7.25 ... 101.53 psi	Relative (gauge) pressure
- pc: 0 ... 30 bar	0.00 ... 435.11 psi	

WARNING: Only use approved pressure transducers.

Recommended basic commissioning steps:

- Verify that the power circuit corresponds to the suggestions on the following pages: 5 ... 6
- In particular ensure that a safety contactor is fitted between the FrigoPack refrigeration inverter and the compressor.
- Verify that the control circuit corresponds to the suggestions on the following pages: 7 ... 9.
- In particular ensure that two isolated contacts of a safety relay are connected to the safety contactor and also to the following input of the FrigoPack refrigeration inverter: DIN7: 13P ... 13.
- Remove Start Command: DIN1: 7P ... 7.
- Connect main power supply.
- Verify that the blue LED near terminals 3A and 3B from the suction pressure transducer lights. If not, then check the wiring to the transducer.
- Verify that the red LED near terminals 2A and 2B from the discharge pressure transducer lights if fitted. If not, then check the wiring to the transducer.
- Measure the pressures with a refrigeration pressure gauge. Verify that the pressure indicated at parameters AP01: and AP03: agree with these external measurements.

Filling with refrigerant:

- Ensure that FrigoPack is not running by putting the control switch in the OFF position or by removing the connection to DIN1 (Terminal 7) .
- Switch to LOCAL mode as follows depending on which keypad is used.
 - Small keypad fitted:
 - Press key 'E' until Rdy is displayed.
 - Press key 'O' until a hand is displayed.
 - Large external keypad used:
 - Press key 'L/R'. LEDs "SEQ" and "REF" should light.
- Start the compressor by pressing the green key 'I'. After the start sequence the compressor will operate at the minimum set frequency.
- Stop the compressor by pressing the red key 'O'.
- Switch back to automatic operation on completion process by removing the electrical power, waiting until the keypad is dark, and then re-applying the electrical power.
- Reconnect DIN1 (Terminal 7) for automatic operation.

Manufacturer	Agent / Partner	Customer	Installation
KIMO RHVAC ControlsLtd Tel.: +49 911-8018778 Fax: +49 911-9976118 applications@frigokimo.com www.frigokimo.com			